

# Specifications for Blanview TFT-LCD Monitor

Version 1.0

(Please be sure to check the specifications latest version.)

MODEL COM57H5M87KTC

Customer's Approval
Signature:
Name:
Section:
Title:
Date:

# ORTUSTECH



ORTUS TECHNOLOGY CO., LTD.

Approved by

M. Sugatani

Approved by

N. Mori

Checked by

G. Jimura

Prepared by

M. Jojo

Version History

Date	Page	Description	
Jul. 3, 2015	-	-	First issue

## Contents

1. Application	.....	4
2. Outline Specifications		
2.1 Features of the Product	.....	5
2.2 Display Method	.....	5
3. Dimensions and Shape		
3.1 Dimensions	.....	7
3.2 Outward Form	.....	8
3.3 Serial Label (S-Label)	.....	10
4. Pin Assignment	.....	11
5. Absolute Maximum Rating	.....	13
6. Recommended Operating Conditions	.....	13
7. Characteristics		
7.1 DC Characteristics	.....	14
7.2 AC Characteristics	.....	15
7.3 Input Timing Characteristics	.....	17
7.4 Driving Timing Chart	.....	18
7.5 Example of Driving Timing Chart	.....	19
8. Description of Operation		
8.1 Power On/Off Sequence	.....	20
8.2 Power On Clear	.....	20
8.3 "DISP" On/Off Sequence	.....	21
9. Circuit		
9.1 Driving Circuit Example (AVDD = 12.0V)	.....	22
9.2 LED Circuit	.....	23
9.3 Touch Panel Circuit	.....	23
10. Characteristics		
10.1 Optical Characteristics	.....	24
10.2 Temperature Characteristics	.....	25
11. Criteria of Judgment		
11.1 Defective Display and Screen Quality	.....	26
11.2 Screen and Other Appearance	.....	27
12. Reliability Test	.....	28
13. Packing Specifications	.....	30
14. Handling Instruction		
14.1 Cautions for Handling LCD panels	.....	31
14.2 Precautions for Handling	.....	32
14.3 Precautions for Operation	.....	32
14.4 Storage Condition for Shipping Cartons	.....	33
14.5 Precautions for Peeling off the Protective film	.....	33
APPENDIX	.....	34

## 1. Application

This Specification is applicable to 14.4cm (5.7 inch) Blanview TFT-LCD monitor for non-military use.

- ◎ ORTUS TECHNOLOGY makes no warranty or assume no liability that use of this Product and/or any information including drawings in this Specification by Purchaser is not infringing any patent or other intellectual property rights owned by third parties, and ORTUS TECHNOLOGY shall not grant to Purchaser any right to use any patent or other intellectual property rights owned by third parties. Since this Specification contains ORTUS TECHNOLOGY's confidential information and copy right, Purchaser shall use them with high degree of care to prevent any unauthorized use, disclosure, duplication, publication or dissemination of ORTUS TECHNOLOGY'S confidential information and copy right.
- ◎ If Purchaser intends to use this Products for an application which requires higher level of reliability and/or safety in functionality and/or accuracy such as transport equipment (aircraft, train, automobile, etc.), disaster-prevention/security equipment or various safety equipment, Purchaser shall consult ORTUS TECHNOLOGY on such use in advance.
- ◎ This Product shall not be used for application which requires extremely higher level of reliability and/or safety such as aerospace equipment, telecommunication equipment for trunk lines, control equipment for nuclear facilities or life-support medical equipment.
- ◎ It must be noted as a mechanical design manner, especial attention in housing design to prevent arcuation/flexure or caused by stress to the LCD module shall be considered.
- ◎ ORTUS TECHNOLOGY assumes no liability for any damage resulting from misuse, abuse, and/or miss-operation of the Product deviating from the operating conditions and precautions described in the Specification.
- ◎ ORTUS TECHNOLOGY is not responsible for any nonconformities and defects that are not specified in this specifications.
- ◎ If any issue arises as to information provided in this Specification or any other information, ORTUS TECHNOLOGY and Purchaser shall discuss them in good faith and seek solution.
- ◎ ORTUS TECHNOLOGY assumes no liability for defects such as electrostatic discharge failure occurred during peeling off the protective film or Purchaser's assembly process.
- ◎ This Product is compatible for RoHS directive.

Object substance	Maximum content [ppm]
Cadmium and its compound	100
Hexavalent Chromium Compound	1000
Lead & Lead compound	1000
Mercury & Mercury compound	1000
Polybrominated biphenyl series (PBB series)	1000
Polybrominated biphenyl ether series (PBDE series)	1000

## 2. Outline Specifications

### 2.1 Features of the Product

- 5.7 inch diagonal display, 1,920 [H] x 480 [V] dots.
- 6-bit 262,144 color display capability.
- Built in Timing generator (TG).
- Long life & High bright white LED back-light.
- Blanview TFT-LCD, improved outdoor readability.

	Indoor		Outdoor	
	Readability	Power Efficiency (Battery Life)	Readability	Power Efficiency (Battery Life)
Transmissive	Good	Good	Fair	Poor
Transflective	Fair	Poor	Good	Good
Blanview	Good	Good	Good	Good

### 2.2 Display Method

Items	Specifications	Remarks
Display type	TN type 262,144 colors. Blanview, Normally white.	
Driving method	a-Si TFT Active matrix. Line-scanning, Non-interlace.	
Dot arrangement	RGB stripe arrangement.	Refer to "Dot arrangement".
Signal input method	6-bit RGB, parallel input.	
Backlight type	Long life & High bright white LED.	
Touch panel	Resistance type, transmissive analog tablet	Surface finishing: Clear

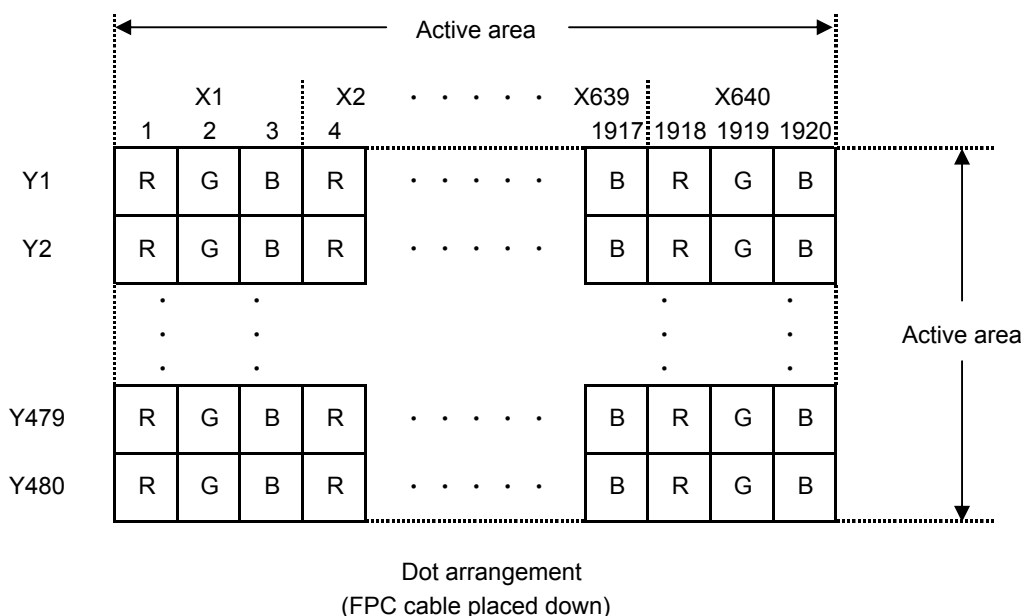

<Features of Blanview>

- Backlight power consumption required to assure visibility. (equivalent to 3.5"QVGA )

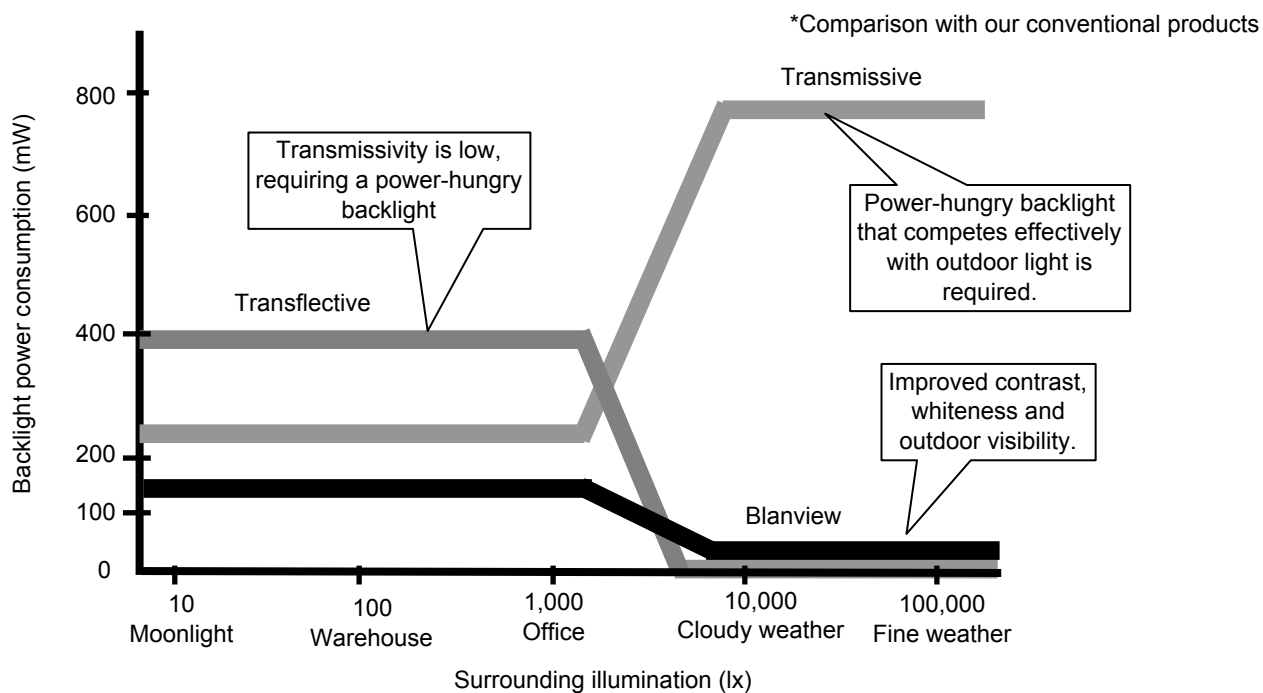

- Contrast characteristics under 100,000lx. (same condition as direct sunlight.)

With better contrast (higher contrast ratio), Blanview TFT-LCD has the best outdoor readability in three different types of TFT-LCD.

Below chart shows contrast value against panel surface brightness. (Horizontal: Panel surface brightness/ Vertical: Contrast value) LCD panel has enough outdoor readability above our Standard line. (ORTUS TECHNOLOGY criteria)

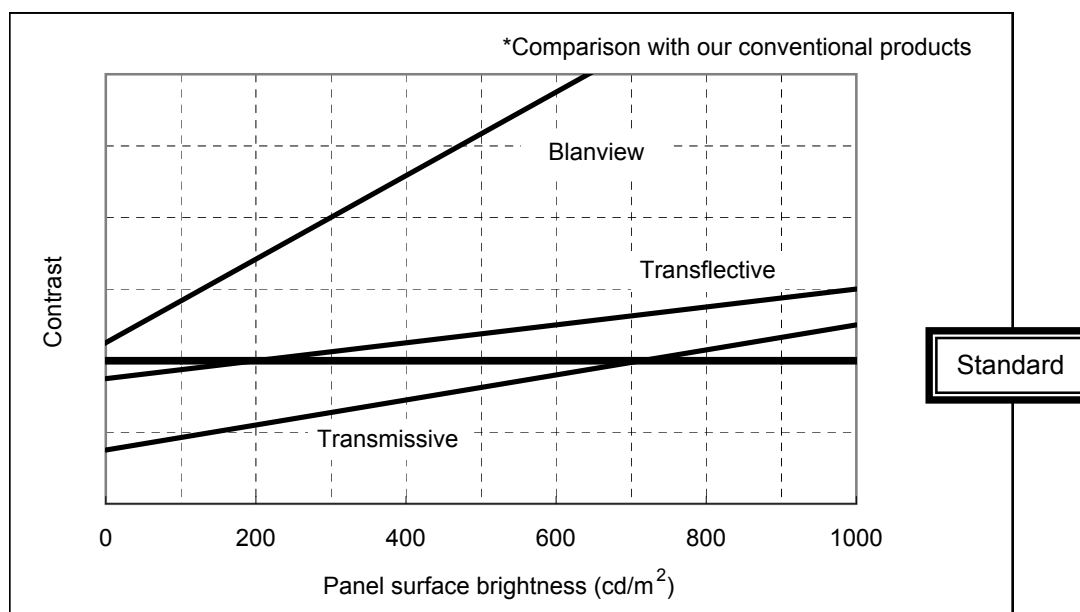

## 3. Dimensions and Shape

## 3.1 Dimensions

Items	Specifications	Unit	Remarks
Outline dimensions	130.32[H] × 101.20[V] × 5.43[D]	mm	Exclude FPC cable.
Active area	115.20[H] × 86.40[V]	mm	14.4cm diagonal.
Number of dots	1,920[H] × 480[V]	dot	
Dot pitch	60.00[H] × 180.00[V]	μm	
Hardness of Touch Panel surface	3	H	Load:4.9N,Angle:45° Reference judgment standard:JIS-K5600
Weight	125	g	Include FPC cable.

EC No.	REV. No.	REVISE	DATE (Y:M:D)	APPROVED	CHECKED	PREPARED
--------	----------	--------	--------------	----------	---------	----------

(8/38)  
14TLM147  
Issue: Jul. 3, 2015

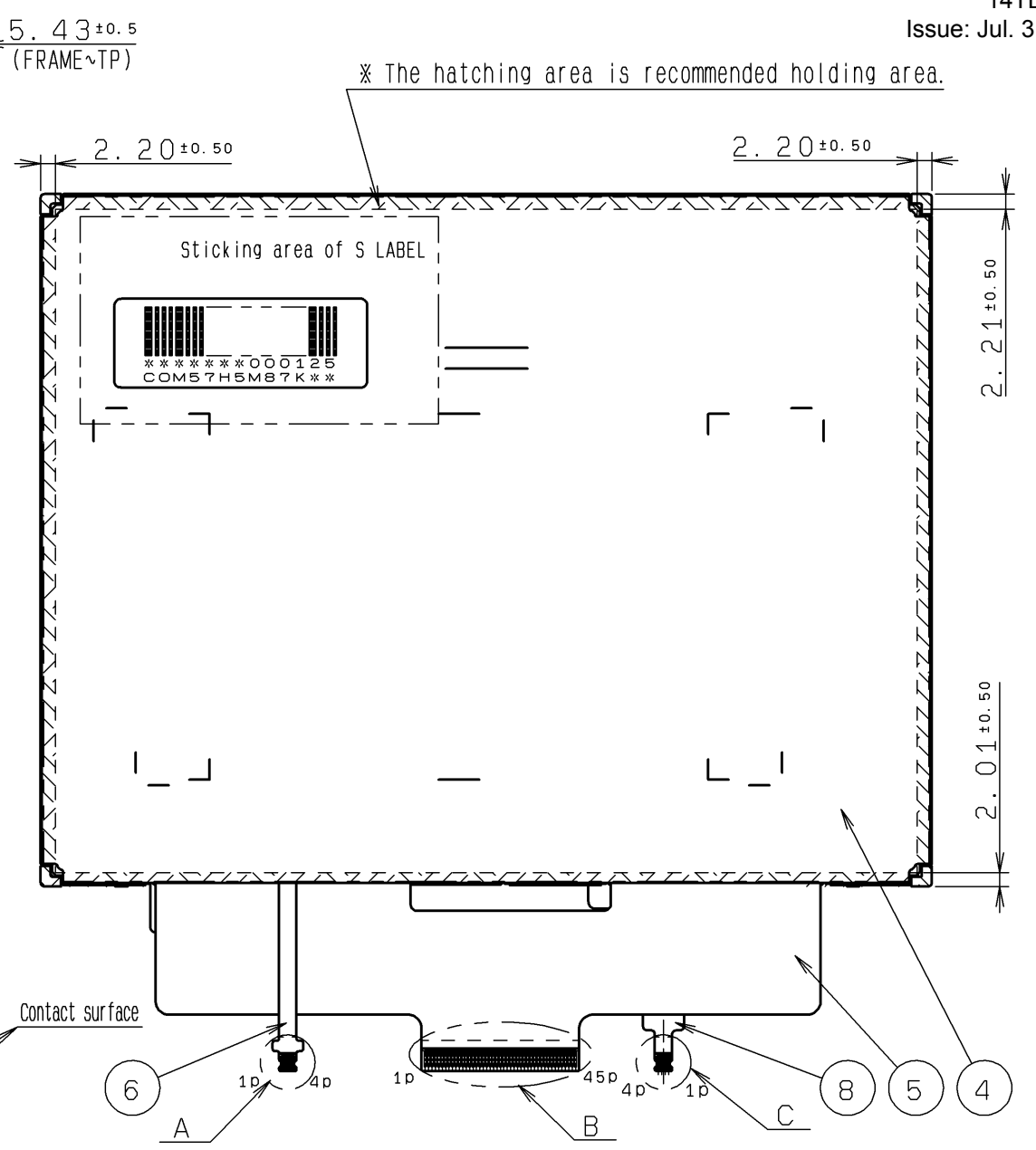
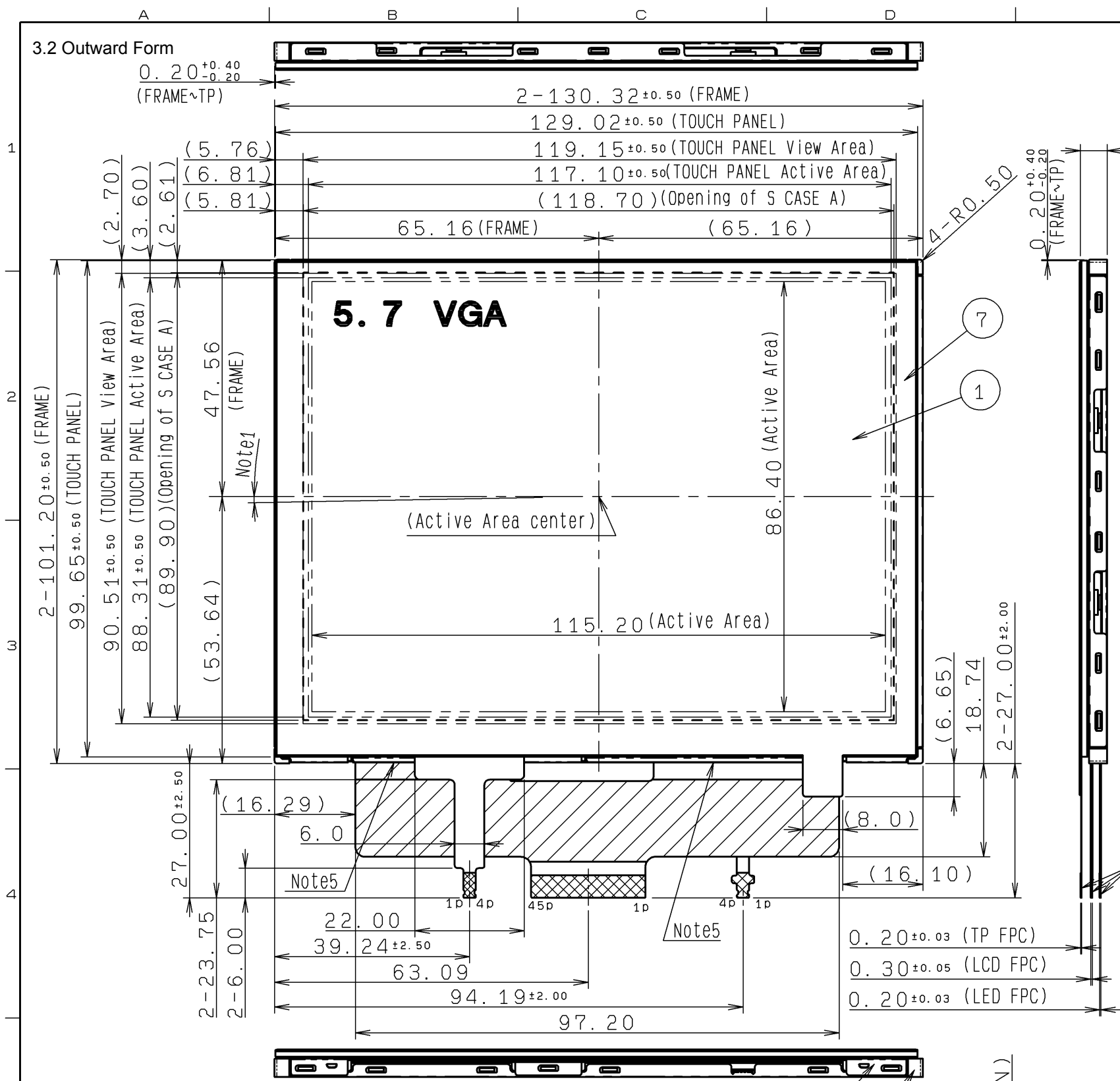

- Note 1. Angular deviation of LCD cell from the TFT-LCD monitor's reference axis shall be less than  $\pm 50'$ .
- Note 2. S label is affixed the area shown in the drawing. The thickness of the S label will be added to that of S case's surface.
- Note 3. Protective film is affixed on front surface of the screen. Location tolerance of the protective film shall be  $\pm 3.0$  mm to the TOUCH PANEL.
- Note 4. Recommended FPC connectors  
 For LCD : Kyocera Connector Products, part number: 04 6240 045 023 846+(Lower contact)  
 For LED FPC: Kyocera Connector Products, part number: 04 6277 004 001 883+(Dual-sided contact)  
 For TP FPC : Kyocera Connector Products, part number: 04 6277 004 001 883+(Dual-sided contact)  
 TP FPC pin assignment differs from a position of Datum Pin of recommended FPC connector. Please notice the difference when designing your circuit with much care.
- Note 5. Exercise care not to apply any forces to the cable holder of the S case A.
- Note 6. Indicated area is recommended holding area.
- Note 7. Refer to "11. CRITERIA OF JUDGMENT" about the appearance specification of a polarizer and touch panel.
- Note 8. Linearity is guaranteed in the area surrounded by 3mm inside lines from TOUCH PANEL Active Area.

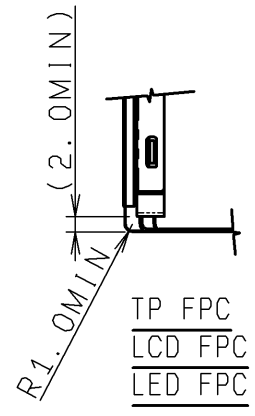

S LABEL	9	Barcode(CODE39)	(37x13x0.075t)
TOUCH PANEL FPC	8		
TOUCH PANEL	7	Film-Glass(1.1t)	Surface finishing : Clear
LED FPC	6		
LCD FPC	5		
S CASE C	4		
FRAME	3		
S CASE A	2		
TFT-LCD PANEL	1	Glass substrate thickness=0.5t	
PART NAME	ITEM	MATERIAL GRADE	REMARK

APPROVED 橋爪	GENERAL TOLERANCE $\pm 1.0$	SCALE 1/1(2/1, 5/1, Free)	UNIT mm	<b>ORTUSTECH</b> ORTUS TECHNOLOGY CO., LTD. DO NOT DUPLICATE. CONFIDENTIAL AND PROPRIETARY
CHECKED 平信	ISSUE (Y:M:D) 15:06:12	MODEL COM57H5M87K**		
CHECKED	NAME			DRAWING No.
DESIGN 小林宣幸				REV.
DRAW 小林宣幸				SHEET
<b>OUTLINE-D5M87</b>				DIV.
				1/2
				PART
				RJD527162D301



EC No.	REV. No.	REVISE	DATE (Y:M:D)	APPROVED	CHECKED	PREPARED
--------	----------	--------	--------------	----------	---------	----------

(9/38)  
14TLM147  
Issue: Jul. 3, 2015

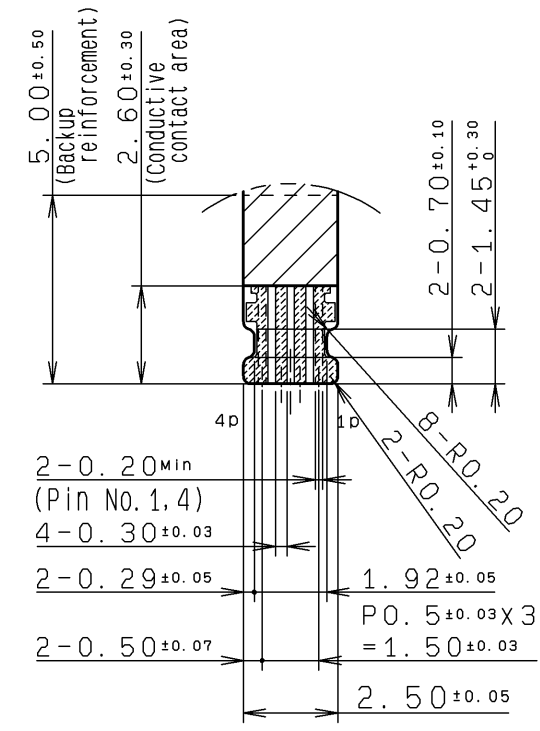

Detail C (S=5/1)

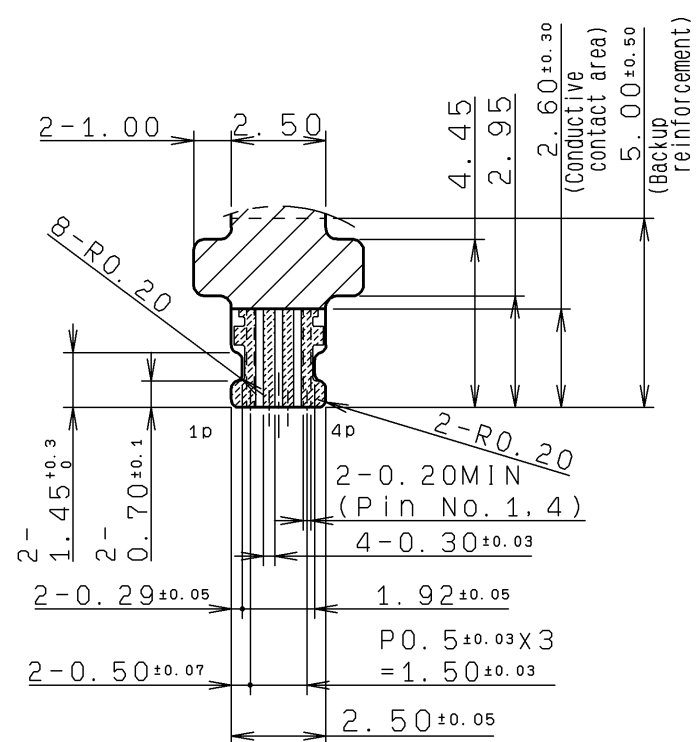

Detail A (S=5/1)

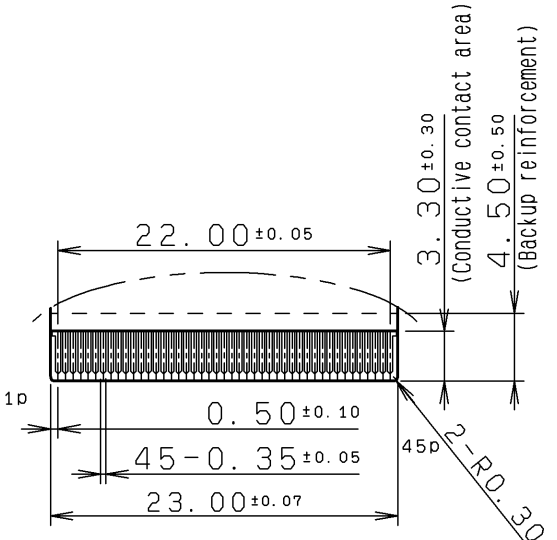

Detail B (S=2/1)

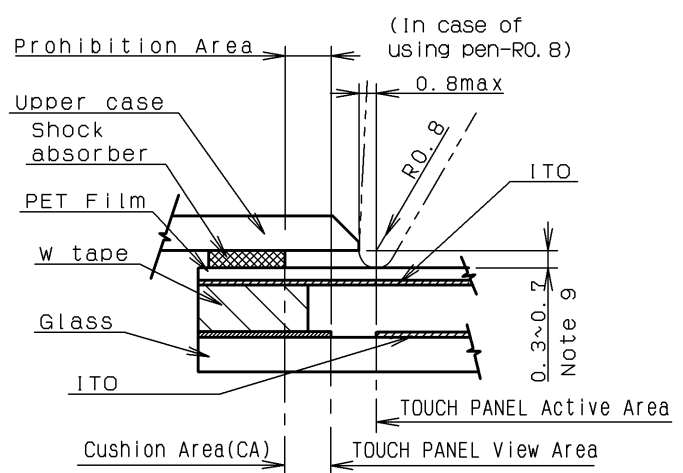

Example of Housing Design (S=Free)

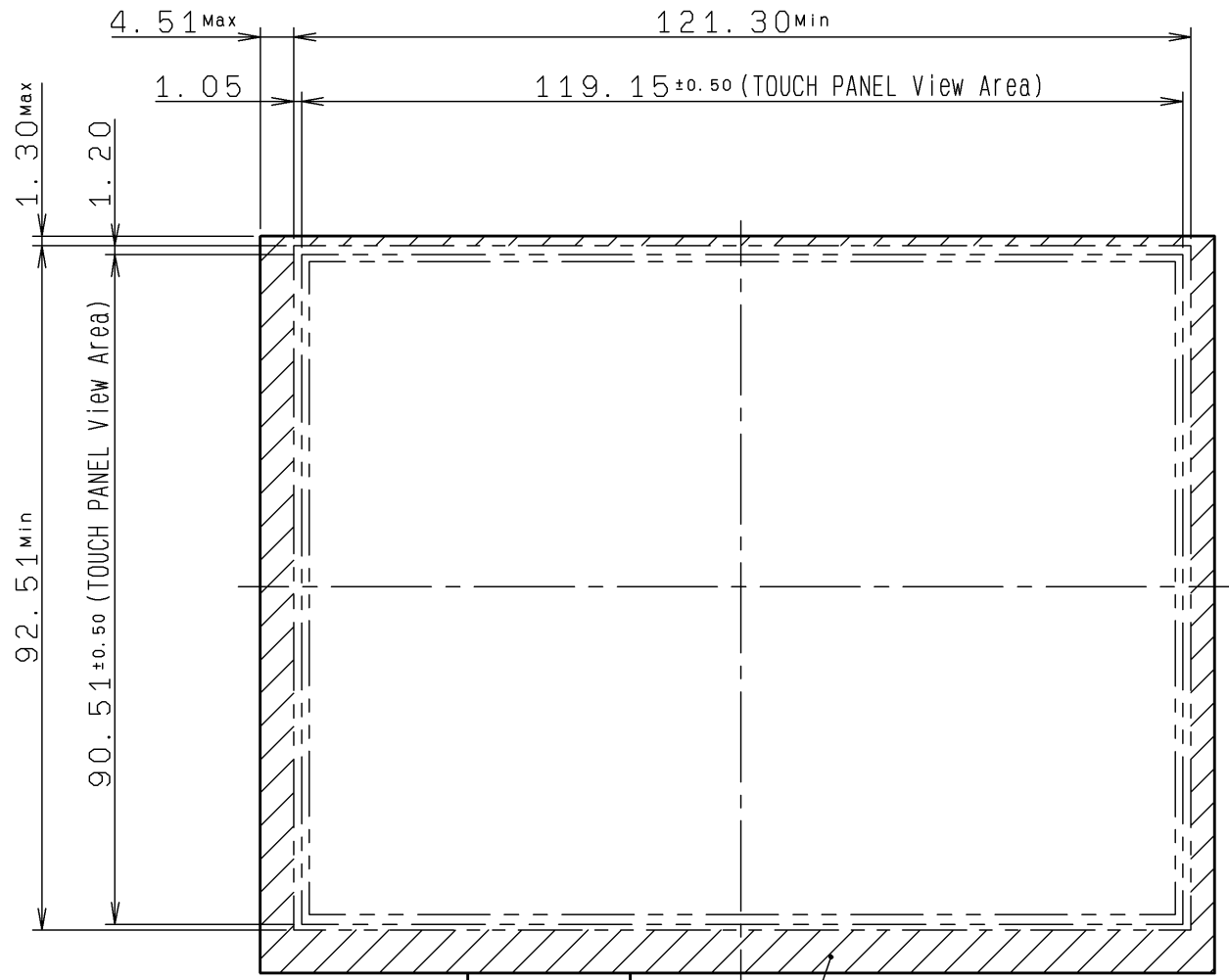

TOUCH PANEL Cushion Area (S=1/1)

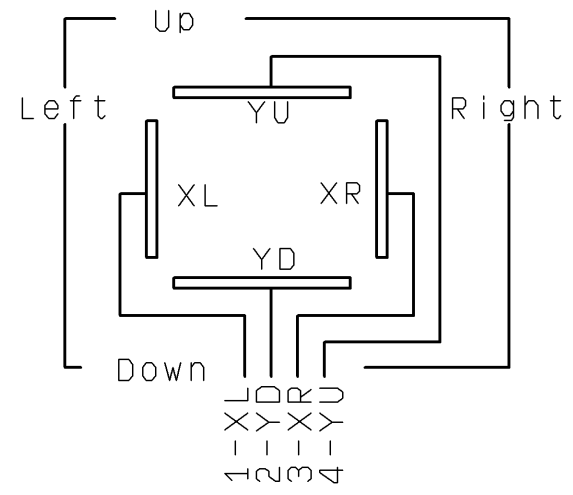

TP Circuit diagram

Design guidance for the Housing & the cushion

- Note 9. Keep a gap, for example 0.3 to 0.7mm between the bezel edge and touch panel surface to avoid the bezel edge from making contacting with the touch panel surface that may cause a "false touch" with the bottom layer.
- Note10. Recommended dimensions of housing in case of using pen(R0.8) (refer to "Example of Housing Design")
- Note11. Upper case opening
- Please place the upper case opening to maintain the operation by a stylus pen inside the TP response area.
  - The any pressures in the area between TP response area and TP viewing area is prohibited.
  - Please use the appropriate material(PMMA,PC,etc.) as the upper case.
- Note12. Cushion design
- Please put the cushion on the upper case.
  - Do not use an adhesive tape to stick on the TP surface.
  - Please position the cushion over the cushion area to avoid a short.

APPROVED	GENERAL TOLERANCE ± 1.0	SCALE 1/1(2/1,5/1,Free)	UNIT mm	<b>ORTUSTECH</b> ORTUS TECHNOLOGY CO., LTD. DO NOT DUPLICATE. CONFIDENTIAL AND PROPRIETARY
CHECKED	ISSUE (Y:M:D) 15:05:29	MODEL COM57H5M87K**		
CHECKED	NAME	<b>OUTLINE-D5M87</b>		DRAWING No.
DESIGN 小林宣幸				REV.
DRAW 小林宣幸				SHEET
				2/2
				PART

### 3.3 SERIAL LABEL (S-LABEL)

#### 1) Display Items

A section : Bar code

B section : Combination of a character

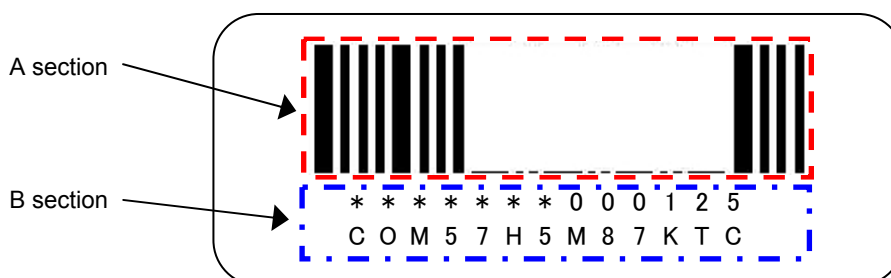

#### Details of B section

Upper column: It indicates The least significant digit of manufacture year (1 digit), manufacture month with below alphabet (1letter), model code (5characters), serial number (6digits).

*	*	*****	*****
-	-		
a	b	c	d

	Contents of display							
a	The least significant digit of manufacture year							
b	Manufacture month	Jan-A	Mar-C	May-E	Jul-G	Sep-I	Nov-K	
		Feb-B	Apr-D	Jun-F	Aug-H	Oct-J	Dec-L	
c	Model code	57FAC (Made in Japan)					57FBC (Made in Malaysia)	
d	Serial number							

\* Example of indication of Serial label (S-label)

•Made in Japan

6A57FAC000125

means "manufactured in Jan. 2015, 5.7" FA type, C specifications, serial number 000125"

•Made in Malaysia

6A57FBC000125

means "manufactured in Jan. 2015, 5.7" FB type, C specifications, serial number 000125"

Lower column: Model (13characters)

#### 2) Location of Serial Label (S-label)

Refer to 3.2 "Outward Form".

#### 3) Others

Bar code readability is excluded from quality assurance coverage.

## 4. Pin Assignment

## 4.1 Display Module Part

No.	Symbol	Function
1	VSS	GND.
2	VGL	Negative voltage for gate driver.
3	VDD	Power supply for logic circuit.
4	VGH	Positive voltage for gate driver.
5	AVDD	Power supply for analog circuit.
6	V10	Source driver output level voltage. (negative case)
7	V6	Source driver output level voltage. (negative case)
8	V5	Source driver output level voltage. (positive case)
9	V1	Source driver output level voltage. (positive case)
10	POCB	Power on clear. (Low: Active)
11	DISP	Display on/off control signal.(Lo :display off, Hi:display on)
12	RL	Horizontally Flipped (right/left) signal. (Lo: Horizontally Flipped Display, Hi: Normal display)
13	UD	Vertically Flipped (up/down) signal. (Lo: Normal display,Hi: Vertically Flipped Display)
14	VSS	GND.
15	VDD	Power supply for logic circuit.
16	DE	Input data effective signal. (It is effective for the period of "Hi")
17	HSYNC	Horizontal sync signal. (Low active)
18	VSYNC	Vertical sync signal. (Low active)
19	CLK	Clock signal.Latching data at the rising edge.
20	TEST5	Short to VSS.
21	TEST6	Short to VSS.
22	D00	Display data(R). 00h: Black D00: LSB D05: MSB  Driver has internal gamma conversion.
23	D01	
24	D02	
25	D03	
26	D04	
27	D05	
28	TEST3	Short to VSS.
29	TEST4	Short to VSS.
30	D10	Display data(G). 00h: Black D10: LSB D15: MSB  Driver has internal gamma conversion.
31	D11	
32	D12	
33	D13	
34	D14	
35	D15	
36	TEST1	Short to VSS.
37	TEST2	Short to VSS.
38	D20	Display data(B). 00h: Black D20: LSB D25: MSB  Driver has internal gamma conversion.
39	D21	
40	D22	
41	D23	
42	D24	
43	D25	
44	VCOM	Input signal for common electrode.
45	VSS	GND.

- Recommended connector: KYOCERA connector products, 6240 series (04 6240 045 023 846+)
- Please make sure to check a consistency between pin assignment in "3.2 Outward Form" and your connector pin assignment when designing your circuit.  
Inconsistency in input signal assignment may cause a malfunction.
- Since FPC cable has gold plated terminals, gilt finish contact shoe connector is recommended.

## 4.2 Backlight Part

No.	Symbol	Function
1	BLH1	Backlight drive 1 (anode side).
2	BLH2	Backlight drive 2 (anode side).
3	BLL2	Backlight drive 2 (cathode side).
4	BLL1	Backlight drive 1 (cathode side).

- Recommended connector: KYOCERA connector products, 6277 series [04 6277 004 001 883+]
- Please make sure to check a consistency between pin assignment in "3.2 Outward Form" and your connector pin assignment when designing your circuit.  
Inconsistency in input signal assignment may cause a malfunction.
- Since FPC cable has gold plated terminals, gilt finish contact shoe connector is recommended.

## 4.3 Touch Panel Part

No.	Symbol	Function
1	XL	X-axis left terminal
2	YD	Y-axis down terminal
3	XR	X-axis right terminal
4	YU	Y-axis up terminal

- Recommended connector: KYOCERA connector products 6277 series [04 6277 004 001 883+]
- Please make sure to check a consistency between pin assignment in "3.2 Outward Form" and your connector pin assignment when designing your circuit.  
Inconsistency in input signal assignment may cause a malfunction.
- Since FPC cable has gold plated terminals, gilt finish contact shoe connector is recommended.

5. Absolute Maximum Rating

VSS=0V

Item	Symbol	Condition	Rating		Unit	Applicable terminal
			MIN	MAX		
Supply voltage for logic	VDD	Ta=25°C	-0.3	7.0	V	VDD
Supply voltage for analog1	AVDD	Note 1	-0.3	13.5	V	AVDD
Supply voltage for analog2	VGH		-0.3	27.0	V	VGH
Supply voltage for analog3	VGL		VGH-27.0	0.3	V	VGL
Supply voltage for analog4 Note 2	Vγ		-0.3	AVDD-0.1	V	V1,V5,V6,V10
Input voltage for logic	VI		-0.3	VDD+0.3	V	CLK,VSYNC,HSYNC,DE D[25:20],D[15:10],D[05:00],RL, UD,TEST1~6,DISP,POCB
Common electrode voltage	VCOM		-0.3	10.0	V	VCOM
LED direction current of order	IL	Ta=25°C	--	35	mA	BLH1 - BLL1,BLH2 - BLL2
		Ta=70°C	--	15		
Touch Panel input voltage	VIT		--	7.0	V	XR,XL,YU,YD
Storage temperature range	Tstg		-30	80	°C	
Storage humidity range	Hstg	Non condensing in an environmental moisture at or less than 40°C90%RH.				

Note1: Please refer to the "Power On/Off Sequence" section of this document.

Note2: AVDD>V1>V5>V6>V10>VSS.

6. Recommended Operating Conditions

VSS=0V

Item	Symbol	Condition	Rating			Unit	Applicable terminal
			MIN	TYP	MAX		
Supply voltage for logic	VDD	Ta=25°C	3.0	3.3	3.6	V	VDD
Supply voltage for analog1	AVDD		11.0	12.0	13.0	V	AVDD
Supply voltage for analog2	VGH		20.0	21.0	22.0	V	VGH
Supply voltage for analog3	VGL		-8.0	-7.0	-6.0	V	VGL
Common electrode voltage Note 1	VCOM		4.2	4.7	5.2	V	VCOM
Contrast range	V1		10.3	10.6	10.9	V	V1
	V5		6.9	7.2	7.5	V	V5
	V6		5.2	5.5	5.8	V	V6
	V10		0.7	0.8	0.9	V	V10
Input voltage for logic	VI		0	--	VDD	V	CLK,VSYNC,HSYNC, DE,D[25:20],D[15:10], D[05:00],RL,UD,DISP, POCB
Operating temperature range	Top	Note 2,3	-20	25	70	°C	Panel surface temperature
Operating humidity range	Hop	Ta≤30°C	20	--	80	%	
		Ta>30°C	Non condensing in an environmental moisture at or less than 30°C80%RH.				

Note1: This range indicates the most probable range for the optimal setting for VCOM.

It does not mean that the optimal settings for VCOM for all monitors will be in this range.

VCOM should be optimized by viewing/using the monitor.

Note2: This monitor is operatable in this temperature range. With regard to optical characteristics, refer to Item "10. CHARACTERISTICS".

Note3: Acceptable Forward Current to LED is up to 15mA, when Ta=+70°C.

Do not exceed Allowable Forward Current shown on the chart below.

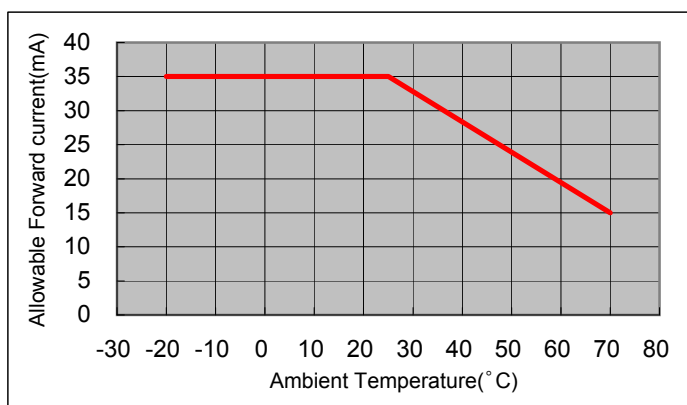

## 7. Characteristics

## 7.1 DC Characteristics

## 7.1.1 Display Module

(Unless otherwise noted, Ta=25°C, VDD=3.3V, VSS=0V)

Item	Symbol	Condition	Rating			Unit	Applicable terminal
			MIN	TYP	MAX		
Input voltage for logic	VIH		0.7×VDD	--	VDD	V	CLK, VSYNC, HSYNC, DE, D[25:20], D[15:10], D[05:00], RL, UD, DISP, POCB
	VIL		0	--	0.3×VDD	V	
Pull up resistor value	Rpu		300	450	600	kΩ	DISP, POCB
Pull down resistor value	Rpd		300	450	600	kΩ	DE, D[25:20], D[15:10], D[05:00], TEST1~6,
Current consumption	IDD	fCLK=25MHz Color bar display	--	7.0	14.0	mA	VDD
	IAVDD	VDD=3.3V AVDD=12.0V	--	14.0	28.0	mA	AVDD
	IGH	VGH=21.0V VGL=-7.0V	--	120	240	μA	VGH
	IGL		-240	-120	--	μA	VGL

## 7.1.2 Backlight

Item	Symbol	Condition	Rating			Unit	Applicable terminal
			MIN	TYP	MAX		
Forward current	IL25	Ta=25°C	--	10.2	35.0	mA	BLH1 - BLL1 BLH2 - BLL2
	IL70	Ta=70°C	--	--	15.0	mA	
Forward voltage	VL	Ta=25°C, IL=10.2mA	--	24.5	25.7	V	
Estimated Life of LED	LL	Ta=25°C, IL=10.2mA Note	--	(50,000)	--	hr	

- Note:
- The lifetime of the LED is defined as a period till the brightness of the LED decreases to the half of its initial value.
  - This figure is given as a reference purpose only, and not as a guarantee.
  - This figure is estimated for an LED operating alone.
- As the performance of an LED may differ when assembled as a monitor together with a TFT panel due to different environmental temperature.
- Estimated lifetime could vary on a different temperature and usually higher temperature could reduce the life significantly.

## 7.1.3 Touch Panel

Ta=25° C

Item	Symbol	Condition	Rating			Unit	Applicable terminal
			MIN	TYP	MAX		
Linearity	LE	Note	-1.5	--	1.5	%	
Insulation resistance	RI	DC 25V	20	--	--	MΩ	XR,XL-YU,YD
Terminal resistance		X	300	--	1000	Ω	XR,XL
		Y	100	--	600		YU,YD
Rated voltage		DC	--	5.0	7.0	V	XR,XL,YU,YD
on/off chattering		R0.8mm Polyacetal pen.	--	--	10	ms	

Note: -Please refer to "3.2 Outward Form" for the range of the guarantee.

-Linearity Measurement: Refer to the APPENDIX of "Reference Method for Measuring Optical Characteristics".

Load: 2.45N

## Mechanical Characteristics

Item	Rating			Unit	Remark
	MIN	TYP	MAX		
Detectable activation force	0.05	--	1.20	N	R0.8mm Polyacetal pen or finger. Resistance between X and Y axis must be equal or lower than 2KΩ.
Keystroke durability	1,000,000	--	--	times	key the same part by silicon rubber. (Touch panel Active area only) -Rubber tip part: R8mm -Load: 2.45N -speed: 2times/second

## 7.2 AC Characteristics

(Unless otherwise noted, Ta=25° C, VDD=3.3V, VSS=0V)

Item	Symbol	Condition	Rating			Unit	Applicable terminal
			MIN	TYP	MAX		
CLK frequency	fCLK		--	25	27	MHz	CLK
CLK Low period	tw1L	0.3×VDD or less.	14.8	--	--	ns	CLK
CLK High period	tw1H	0.7×VDD or more.	14.8	--	--	ns	CLK
Setup time	tsp		10	--	--	ns	CLK,DE,D[25:20],
Hold time	thd		10	--	--	ns	D[15:10],D[05:00], HSYNC,VSU

Switching Waveform Characteristics

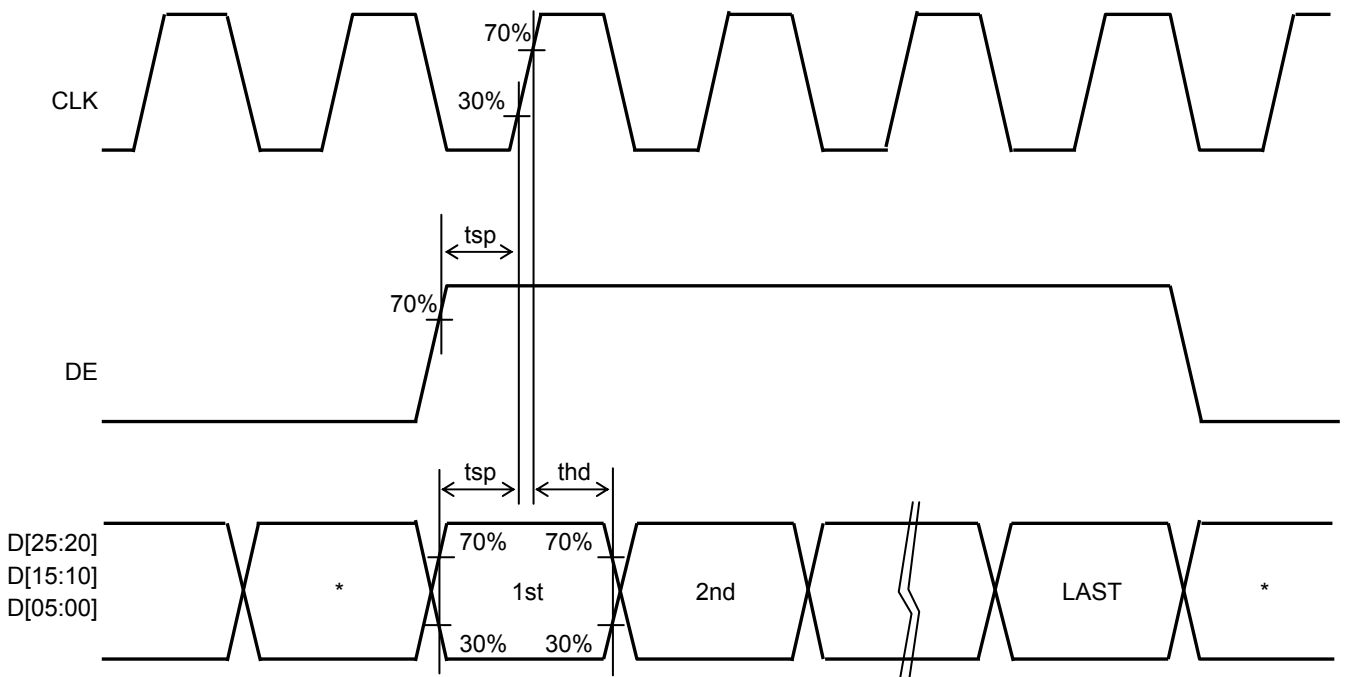
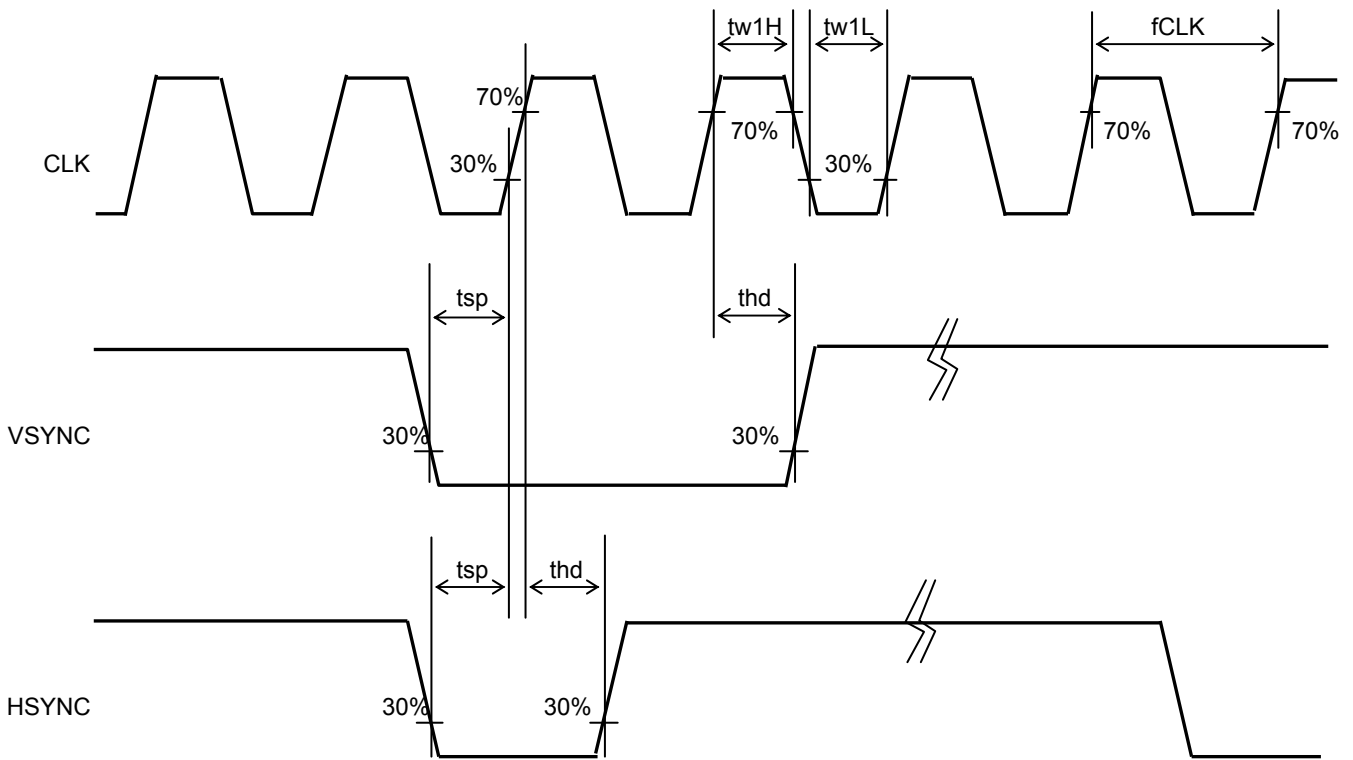

\*:INVALID



## 7.3 Input Timing Characteristics

Item	Symbol	Rating			Unit	Applicable terminal
		MIN	TYP	MAX		
CLK frequency	fCLK	--	25	27	MHz	CLK
VSYNC signal cycle time	tv	--	525	--	H	VSYNC,HSYNC
VSYNC frequency	fVSYNC	54	60	66	Hz	VSYNC
VSYNC pulse width	tw2H	1	3	5	H	VSYNC,HSYNC
Vertical back porch	tvb	--	35	--	H	VSYNC,HSYNC,DE,D[25:20],
Vertical display period	tvdp	--	480	--	H	D[15:10],D[05:00]
HSYNC signal cycle time	th	--	800	--	CLK	HSYNC,CLK
HSYNC pulse width	tw3H	5	30	--	CLK	
Horizontal back porch	thb	112	--	144	CLK	HSYNC,CLK,DE,D[25:20],
				Note 2		D[15:10],D[05:00]
Horizontal display period	thdp	--	640	--	CLK	
DE pulse width	tw4H	--	640	--	CLK	DE,CLK

Note1: The characteristic of this item is recommended standard.

Please use it after it confirms it enough like the display fineness etc.

When it comes off from this characteristic and it is used.

Note2: When "DE" keeps "Lo" for 144CLK or longer,start capturing data automatically from 144CLK.

### 7.4 Driving Timing Chart

#### -Vertical Timing

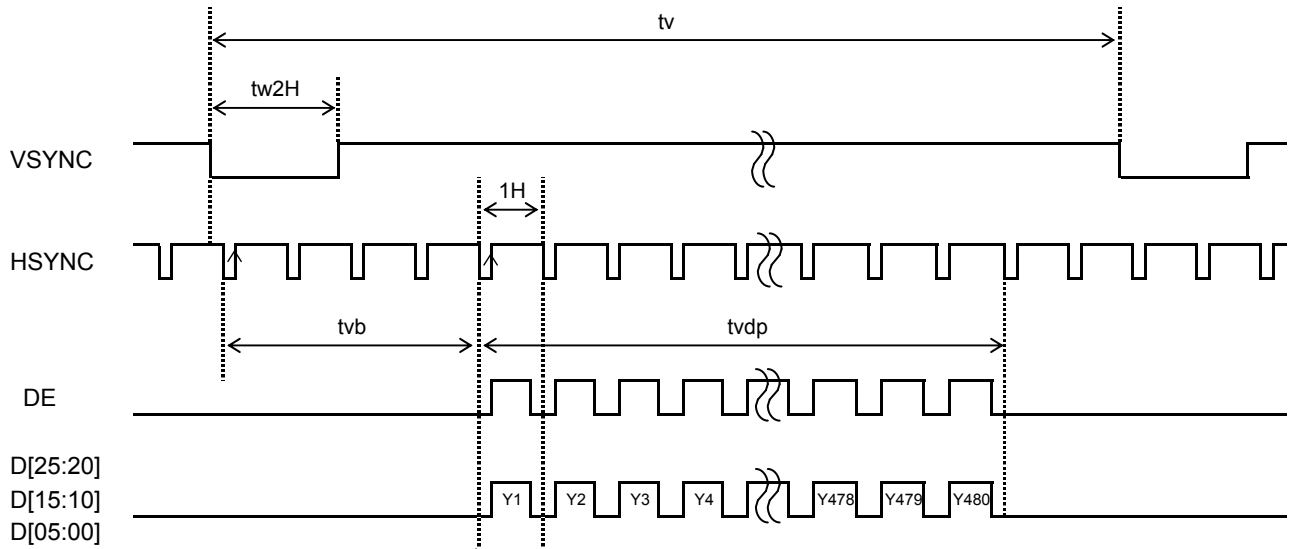

#### -Horizontal Timing

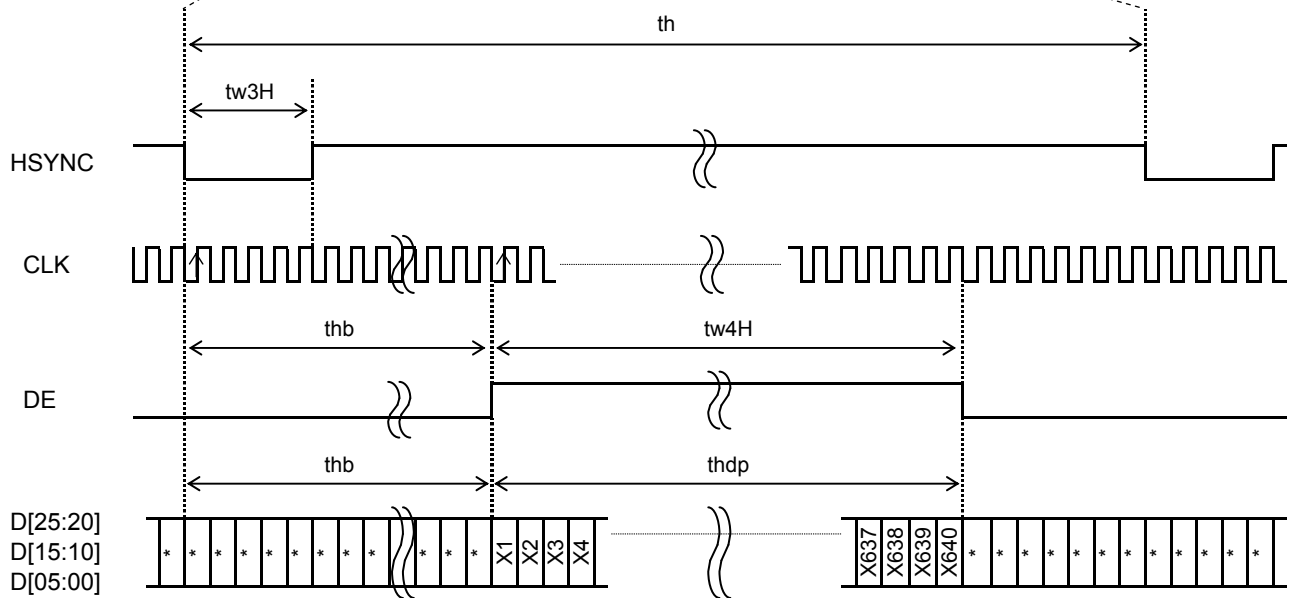

7.5 Example of Driving Timing Chart (fCLK=25MHz)

-Vertical Timing

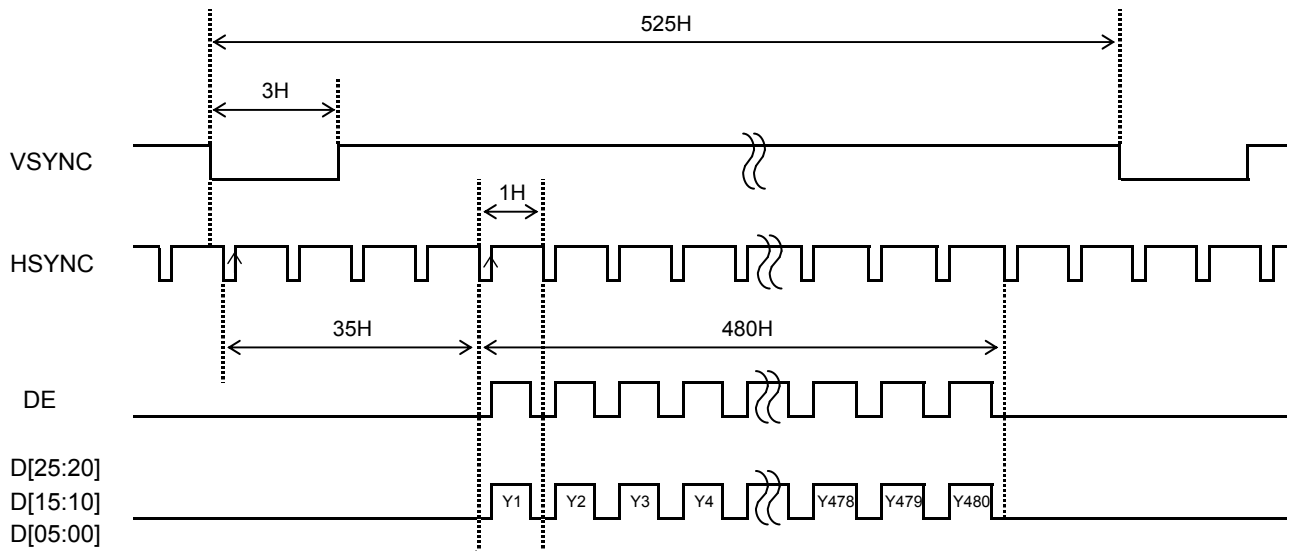

-Horizontal Timing

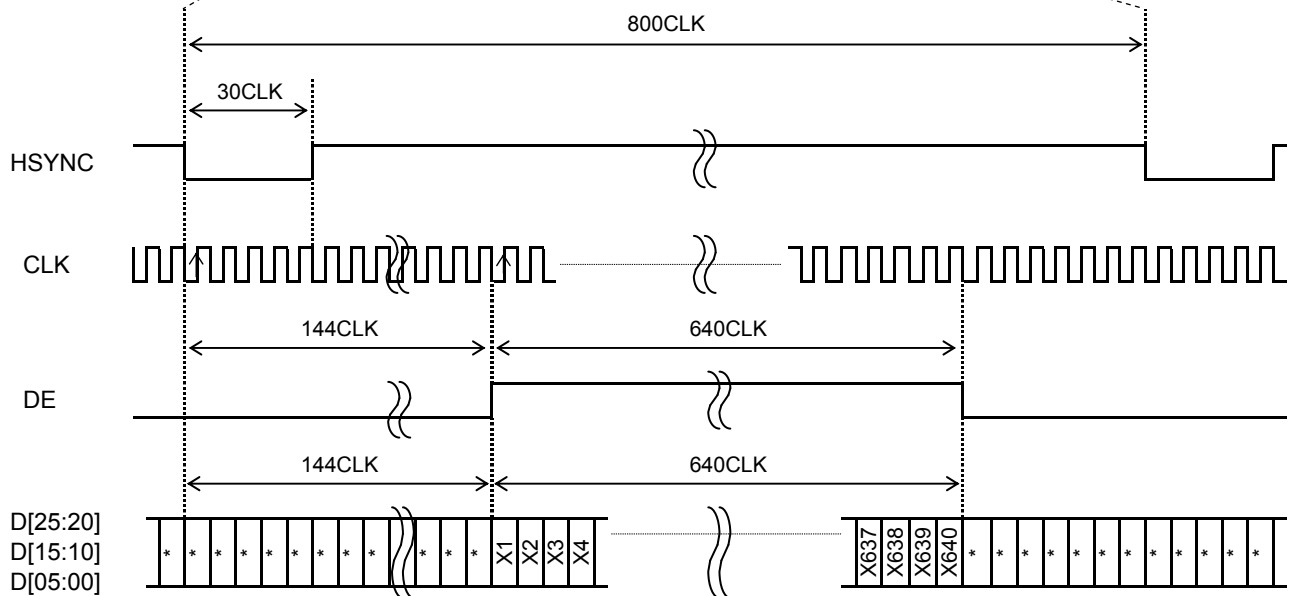

## 8. Description of Operation

### 8.1 Power On/Off Sequence

The sequence of the Power On/Off and the signal input must depend on the following conditions.

- Please input the logic signal after turning on VDD.
- Please input AVDD after turning on VDD or at the same time.
- Please input V1, V5, V6, V10 and VCOM voltage after turning on AVDD.
- Please input VGL after turning on VDD.
- Please input VGH after turning on VGL.

Power Off sequence is assumed to be opposite of the above mentioned sequence.

Please refer Power On/Off recommended sequence is shown in the figure below.

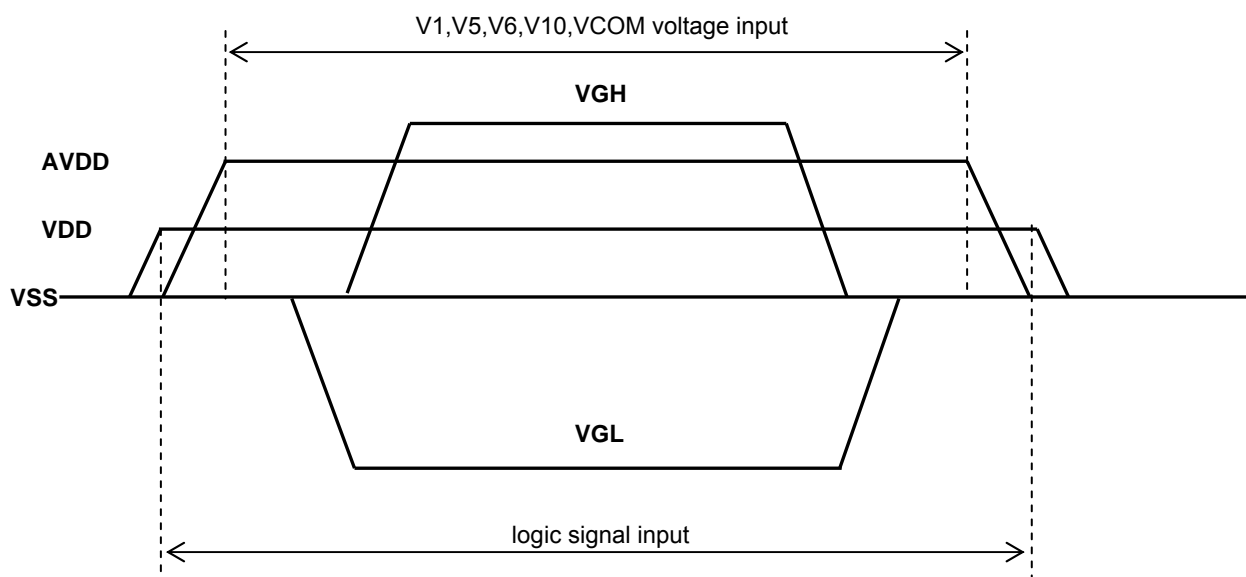

### 8.2 Power On Clear

There is a limitation between Power On and POCB (power on clear).

Please depend on the following conditions.

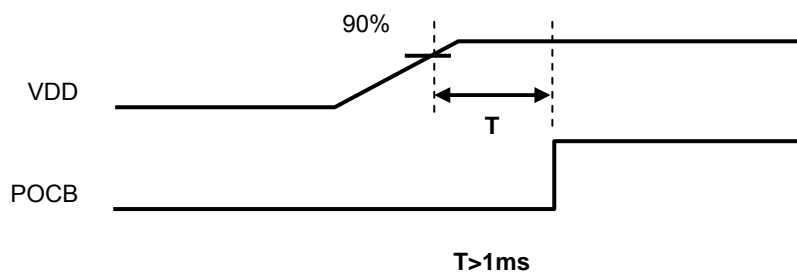

### 8.3 "DISP" On/Off Sequence

It explains the Display on/off sequence.

After Display on, "White" data is outputted for 16-Frames first, from the falling edge of the following VSYNC signal.

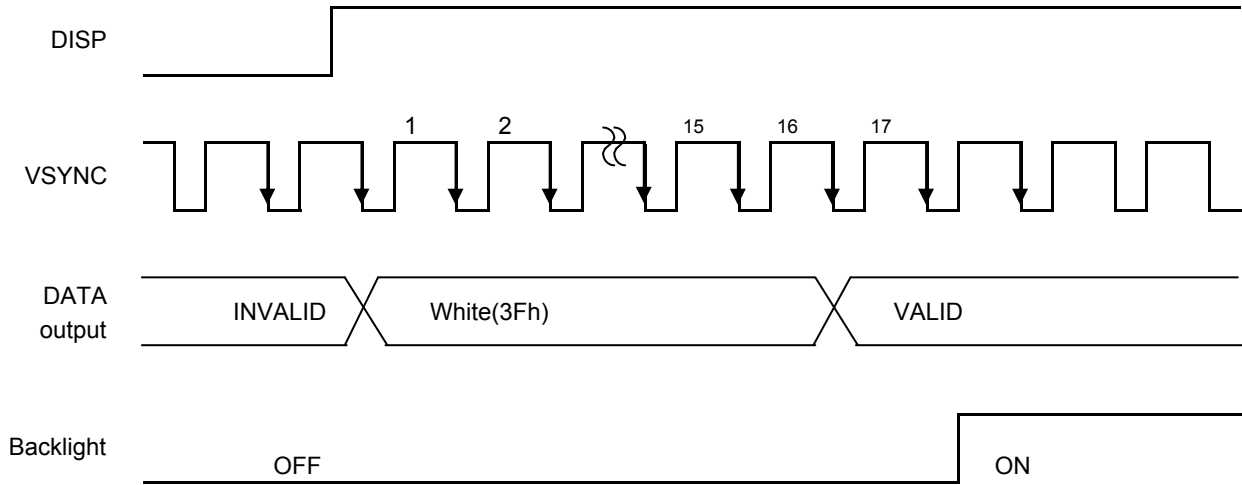

After Display off, "White" data is outputted for 5-Frames first, from the falling edge of the following VSYNC signal. Please turn off the power supply promptly after OFF of "DISP".

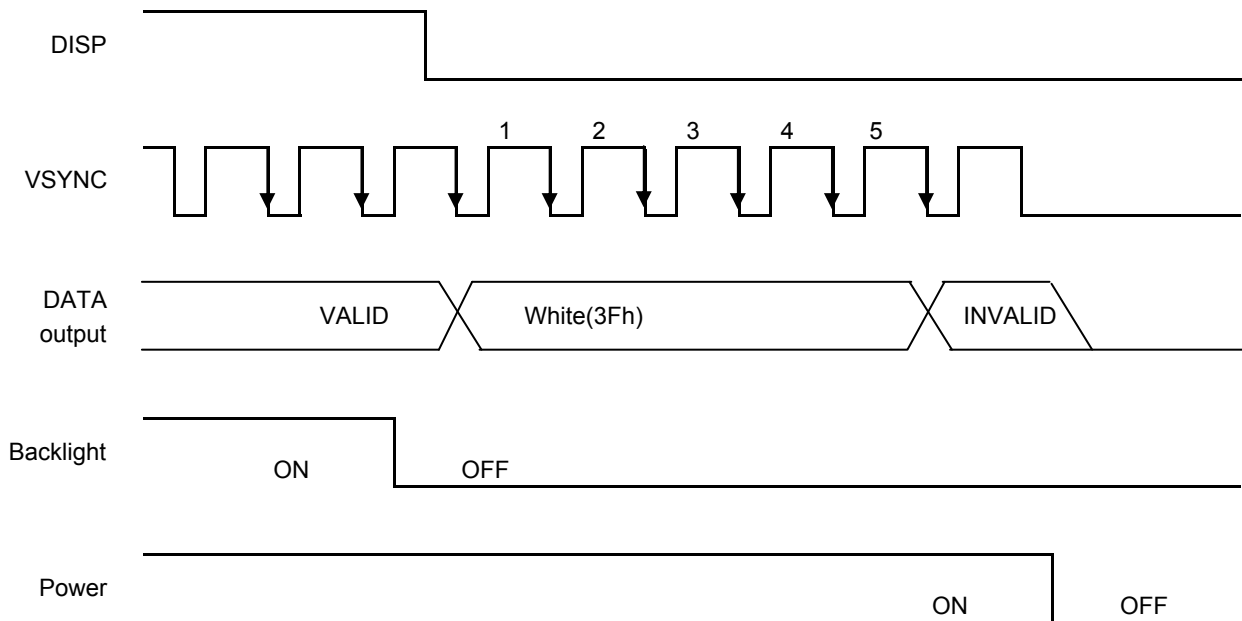

9. Circuit

9.1 Driving Circuit Example (AVDD = 12.0V)

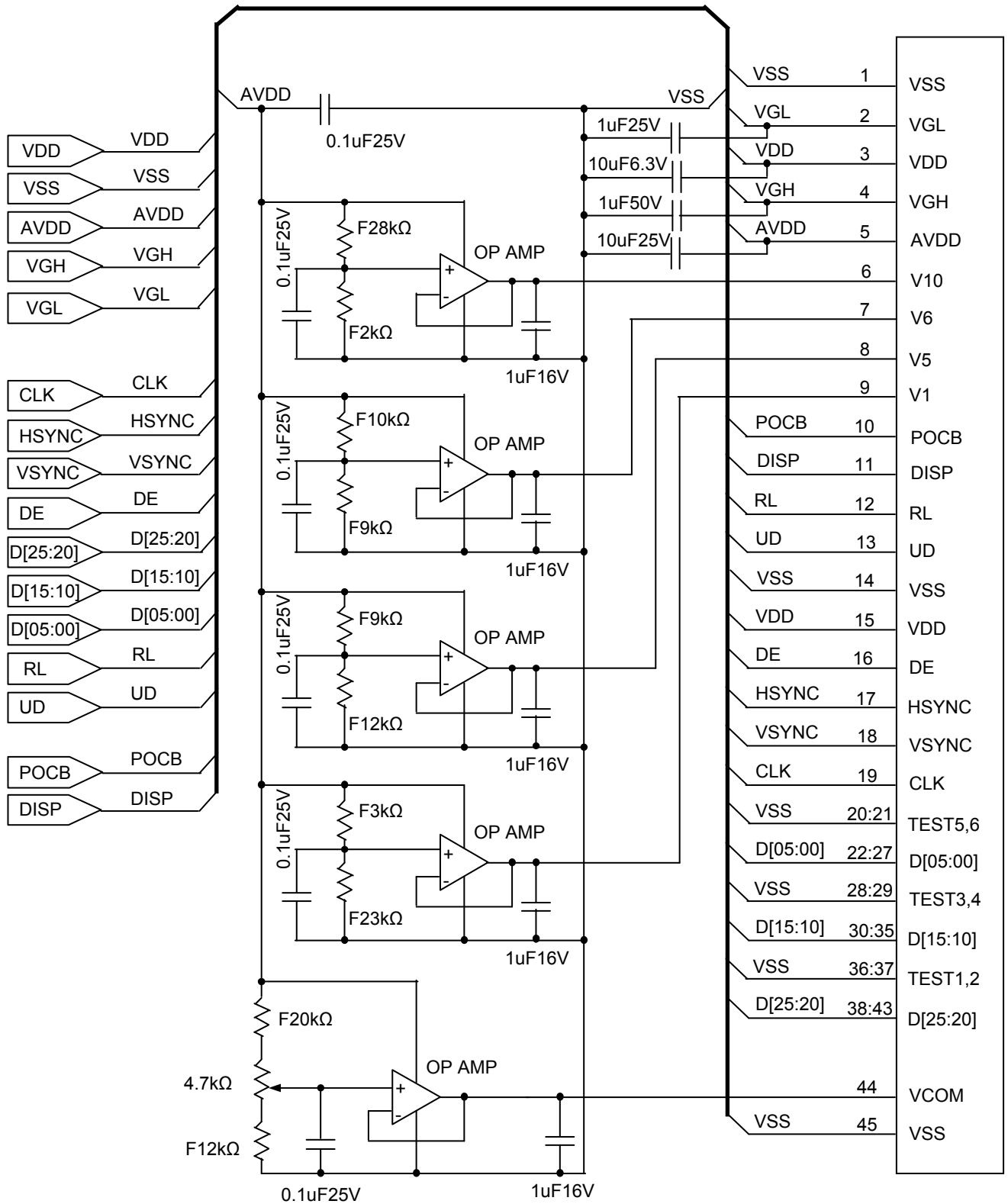

Example of OP AMP: NJM2742M

TFT-LCM Reference Circuit

This circuit design is for reference purposes only. Appropriate component values may be different. Please evaluate on your side.

9.2 LED Circuit

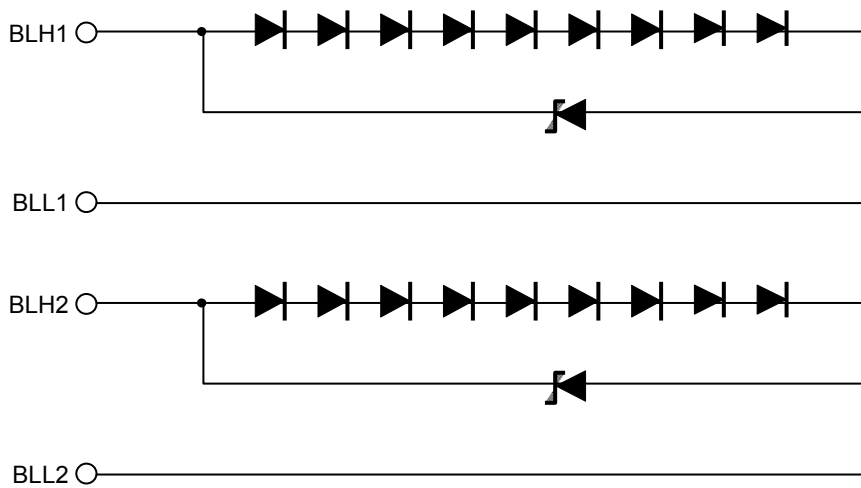

9.3 Touch Panel Circuit

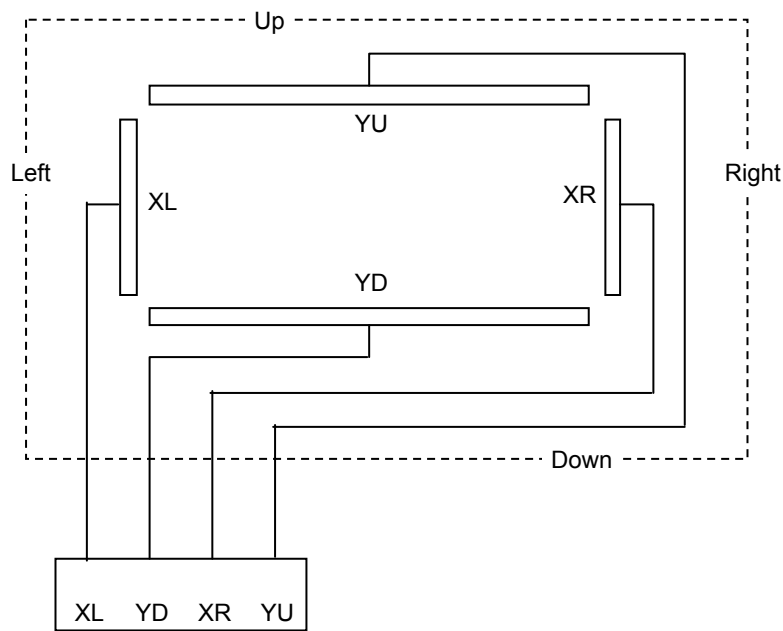

## 10. Characteristics

## 10.1 Optical Characteristics

&lt; Measurement Condition &gt;

Measuring instruments: CS1000 (KONICA MINOLTA) , LCD7200(OTSUKA ELECTRONICS) ,  
EZcontrast160D (ELDIM)

Driving condition: Typical Rating of "6. Recommended Operating Conditions".  
Optimized VCOMDC

Backlight: IL=10.2mA

Measured temperature: Ta=25° C

Item		Symbol	Condition	MIN	TYP	MAX	Unit	Note No.	Remark
Response time	Rise time	TON	[Data]= 3Fh→00h	—	—	40	ms	1	※
	Fall time	TOFF	[Data]= 00h→3Fh	—	—	60	ms		
Contrast ratio	Backlight ON	CR	[Data]= 3Fh/00h	360	600	—		2	
	Backlight OFF			—	2.3	—			
Viewing angle	Left	θL	[Data]= 3Fh/00h CR≥10	—	80	—	deg	3	※
	Right	θR		—	80	—	deg		
	Up	φU		—	60	—	deg		
	Down	φD		—	65	—	deg		
White Chromaticity	x	y	[Data]=3Fh	White chromaticity range				4	
Burn-in				No noticeable burn-in image shall be observed after 0.5 hours of window pattern display.				5	
Center brightness			[Data]=3Fh	300	450	—	cd/m <sup>2</sup>	6	
Brightness distribution			[Data]=3Fh	70	—	—	%	7	

\* Note number 1 to 7: Refer to the APPENDIX of "Reference Method for Measuring Optical Characteristics".

※ Measured in the form of LCD module.



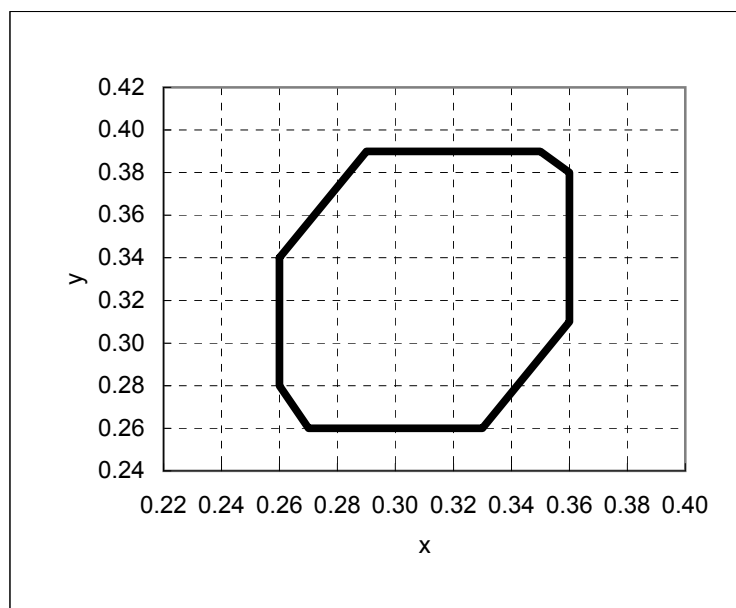

White Chromaticity Range

【White Chromaticity Range】

x	y
0.26	0.34
0.26	0.28
0.27	0.26
0.33	0.26
0.36	0.31
0.36	0.38
0.35	0.39
0.29	0.39

## 10.2 Temperature Characteristics

< Measurement Condition >

Measuring instruments: CS1000 (KONICA MINOLTA) , LCD7200(OTSUKA ELECTRONICS)

Driving condition: Typical Rating of "6. Recommended Operating Conditions".

Optimized VCOMDC

Backlight: IL=10.2mA

Item		Specification		Remark	
		Ta = -20 °C	Ta = 70 °C		
Contrast ratio	CR	40 or more	40 or more	Backlight ON	
Response time	Rise time	TON	200 msec or less	30 msec or less	※
	Fall time	TOFF	300 msec or less	50 msec or less	※
Display Quality		No noticeable display defect or nonuniformity should be observed.		Use the criteria for judgment specified in the section 11.	

※ Measured in the form of LCD module.

11. Criteria of Judgment

11.1 Defective Display and Screen Quality

Test Condition: Observed TFT-LCD monitor from front during operation with the following conditions  
 Driving Signal Raster Patter (RGB, white, black)  
 Signal condition [Data]: 3Fh, 18h, 00h (3 steps)  
 Observation distance 30 cm  
 Illuminance 200 to 350 lx  
 Backlight IL=10.2mA

Defect item	Defect content		Criteria		
Display Quality	Line defect	Black, white or color line, 3 or more neighboring defective dots	Not exists		
	Dot defect	Uneven brightness on dot-by-dot base due to defective TFT or CF, or dust is counted as dot defect (brighter dot, darker dot)	Refer to table 1		
		High bright dot: Visible through 2% ND filter at [Data]=00h Low bright dot: Visible through 5% ND filter at [Data]=00h Dark dot: Appear dark through white display at [Data]=18h Invisible through 5% ND filter at [Data]=00h		ignored	
Screen Quality	Dirt	Uneven brightness (white stain, black stain etc)	Invisible through 1% ND filter		
	Foreign particle	Point-like	0.25mm < φ	N=0	
			0.20mm < φ ≤ 0.25mm	N ≤ 2	
			φ ≤ 0.20mm	Ignored	
	Flaw	Liner	3.0mm < length and 0.08mm < width	N=0	
			length ≤ 3.0mm or width ≤ 0.08mm	Ignored	
			Flaw on the surface of the Touch panel	0.05mm < W	Conform to the criteria of point-like foreign particles.
				0.03 < W ≤ 0.05mm	2 < L ≤ 5mm
		L ≤ 2mm	Ignored		
		W ≤ 0.03mm	Ignored		
Others			Use boundary sample for judgment when necessary		

φ(mm): Average diameter = (major axis + minor axis)/2  
 Permissible number: N

Table 1

Area	High bright dot	Low bright dot	Dark dot	Total	Criteria
A	0	2	2	3	Permissible distance between same color bright dots (includes neighboring dots): 3 mm or more Permissible distance between same color high bright dots (includes neighboring dots): 5 mm or more
B	2	4	4	6	
Total	2	4	4	7	

<Landscape model>

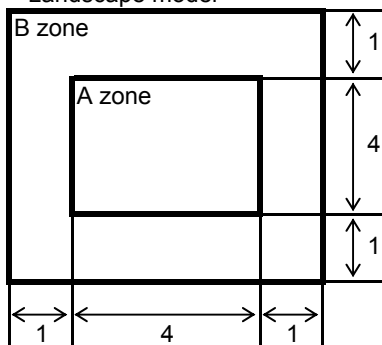

Division of A and B areas  
 B area: Active area  
 Dimensional ratio between A and B areas: 1: 4: 1 (Refer to the left figure)

## 11.2 Screen and Other Appearance

## Testing conditions

Observation distance

30cm

Illuminance

1200~2000 lx

Item	Criteria	Remark
Polarizer Flaw Stain Bubble Dust Dent	Ignore invisible defect when the backlight is on.	Applicable area: Active area only (Refer to the section 3.2 "Outward form")
S-case	No functional defect occurs	
FPC cable	No functional defect occurs	

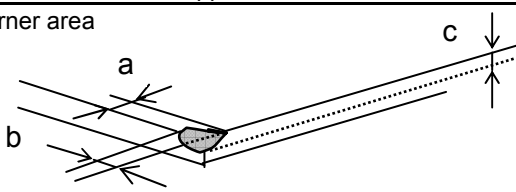
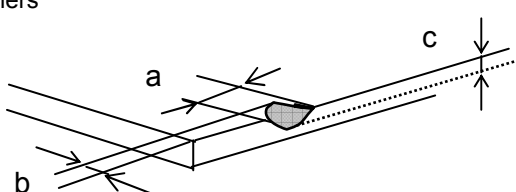
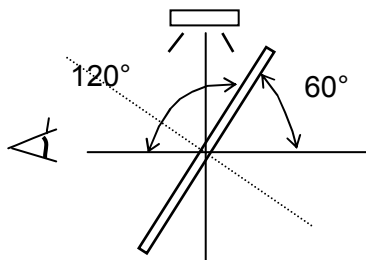
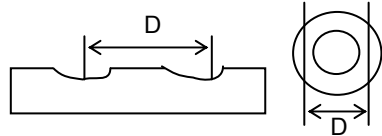
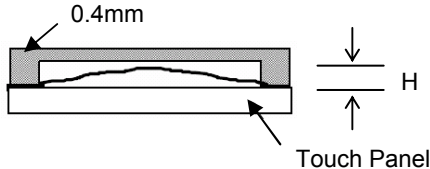
Item	Appearance	Criteria
Touch Panel	Corner area 	Unit:mm $a \leq 3$ $b \leq 3$ $c \leq t$ (t: glass thickness) a,b $\leq 0.5$ is ignored $n \leq 2$
	Others 	Unit:mm $a \leq 5$ $b \leq 1$ $c \leq t$ (t:glass thickness) a,b $\leq 0.5$ is ignored Maximum permissible number of chipping off on a side is 5.
	Progressive crack	None
	Concentric interference fringe (Test method) Observe the Panel surface from 60 degrees angle to the surface under white fluorescent lamp (Triple wavelength lamp) 	Size: 1/3 or less of Active area. Darkness: comply with the boundary sample.
	Fisheye Film surface 	$D \leq \phi 0.2\text{mm}$ Ignored $\phi 0.2 < D \leq \phi 0.6\text{mm}$ $N \leq 2$ $\phi 0.6\text{mm} < D$ $N = 0$
Puffiness 	$H \leq 0.4\text{mm}$ is acceptable.	

## 12. Reliability Test

Test item		Test condition		number of failures /number of examinations
Durability test	High temperature storage	Ta=80°C	240hr	0/3
	Low temperature storage	Ta=-30°C	240hr	0/3
	High temperature & high humidity storage	Ta=60°C, RH=90% non condensing	240hr	0/3
	High temperature operation	Tp=70°C	240hr	0/3
	Low temperature operation	Tp=-20°C	240hr	0/3
	High temp & humid operation	Tp=40°C, RH=90% non condensing	240hr	0/3
	Thermal shock storage	-30↔80°C(30min/30min)	100 cycles	0/3
Mechanical environmental test	Electrostatic discharge test (Non operation)	Confirms to EIAJ ED-4701/300 C=200pF,R=0Ω,V=±200V Each 3 times of discharge on and power supply and other terminals.		0/3
	Surface discharge test (Non operation)	C=250pF, R=100Ω, V=±12kV Each 5 times of discharge in both polarities on the center of screen with the case grounded.		0/3
	FPC tension test (FPC of LCD only)	Pull the FPC with the force of 3N for 10 sec. in the direction +/- 90-degree to its original direction.		0/3
	FPC bend test (FPC of LCD only)	Pull the FPC with the force of 3N for 10 sec. in the direction +/-180-degree to its original direction. Reciprocate it 3 times.		0/3
	Vibration test	Total amplitude 1.5mm, f=10~55Hz, X,Y,Z directions for each 2 hours		0/3
	Impact test	Use ORTUS TECHNOLOGY original jig (see next page)and make an impact with peak acceleration of 1000m/s <sup>2</sup> for 6 msec with half sine-curve at 3 times to each X, Y, Z directions in conformance with JIS C 60068-2-27-2011.		0/3
Packing test	Packing vibration-proof test	Acceleration of 19.6m/s <sup>2</sup> with frequency of 10→55→10Hz, X,Y, Zdirection for each 30 minutes		0/1 Packing
	Packing drop test	Drop from 75cm high. 1 time to each 6 surfaces, 3 edges, 1 corner		0/1 Packing

Note: Ta=ambient temperature Tp=Panel temperature

※ The profile of high temperature/humidity storage and High Temperature/humidity operation  
(Pure water of over 10MΩ·cm shall be used.)

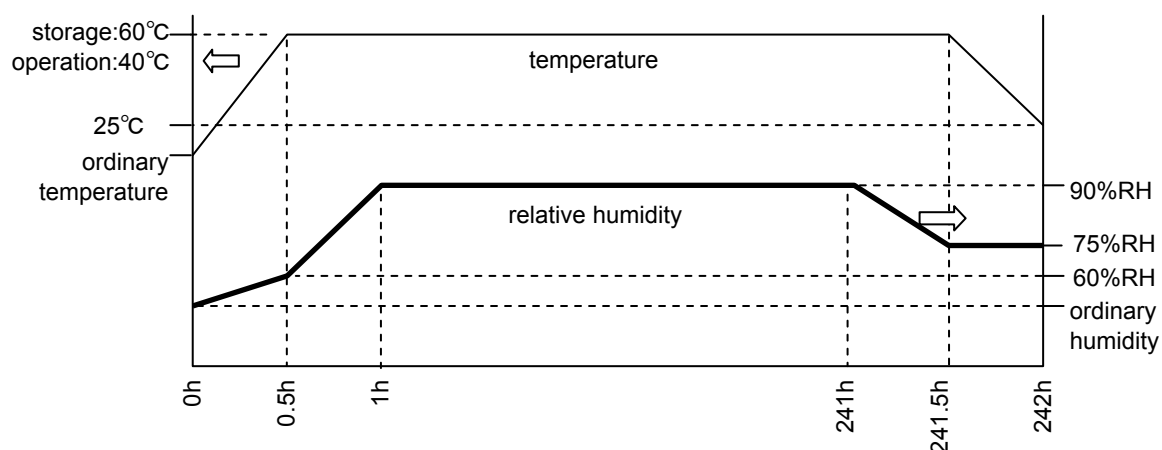
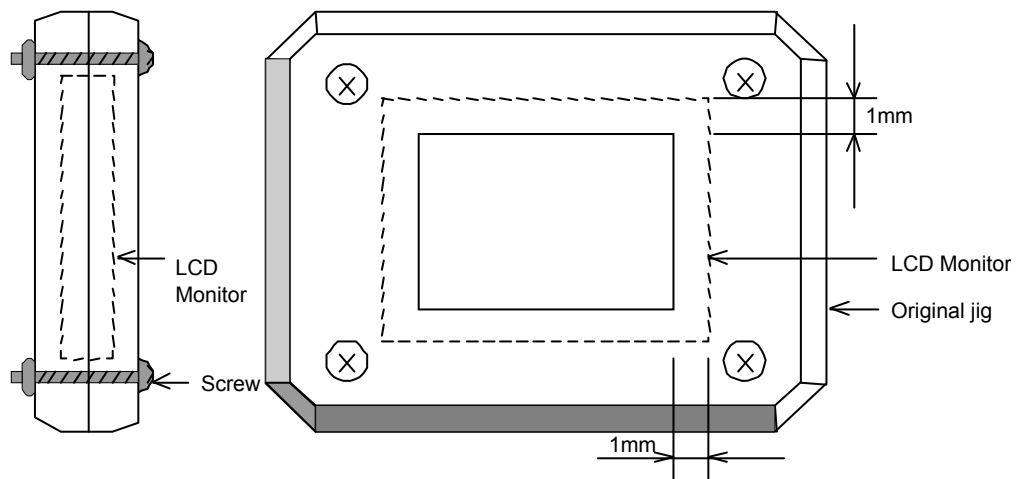

Table2.Reliability Criteria

Measure the parameters after leaving the monitor at the ordinary temperature for 24 hours or more after the test completion.

item	Standard	Remarks
Display quality	No visible abnormality shall be seen.	
Contrast ratio	40 or more	Backlight ON

ORTUS TECHNOLOGY Original Jig



Tension Test Method for FPC cable

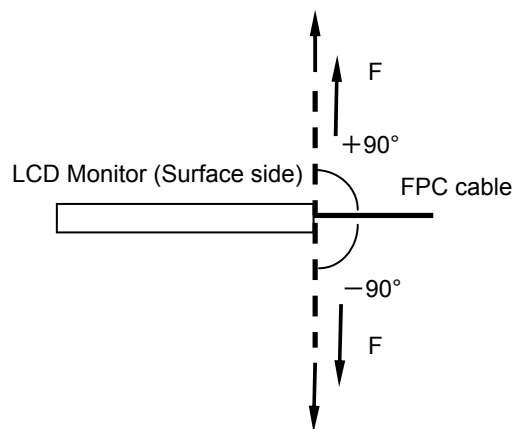

Bend Test Method for FPC cable

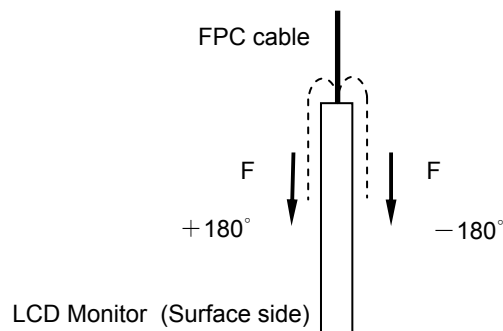

### 13. Packing Specifications

Packing specification  
(S=FREE)

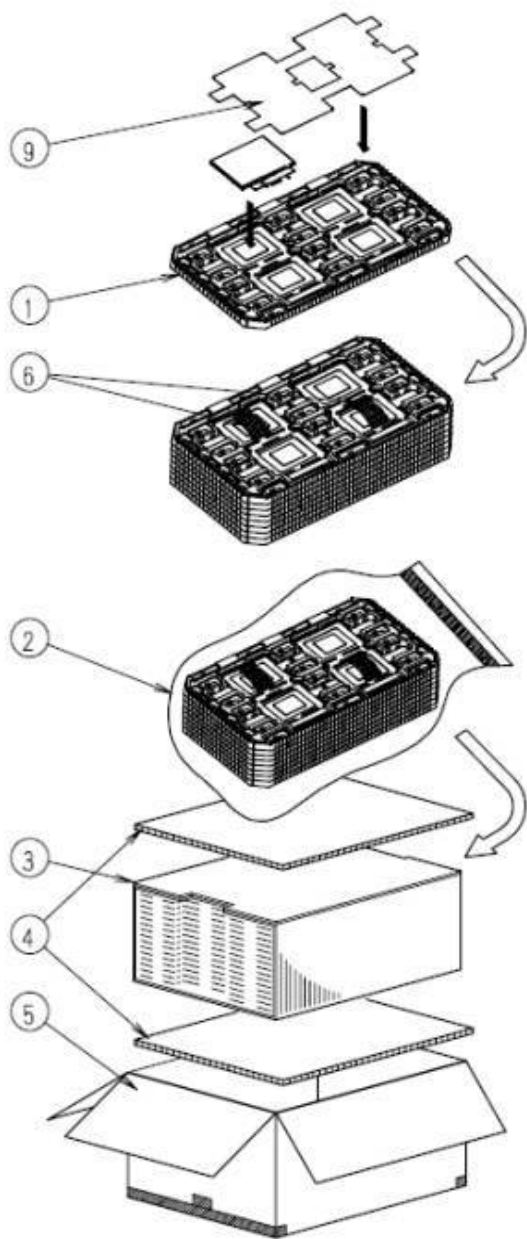

- Step 1. Each product is to be placed in one of the cut-outs of the tray with the display surface facing upward.  
(4 products per tray)
- Step 2. Each tray is to be piled up in same orientation and the trays be in a stack of 7.  
One empty tray is to be put on the top of stack of 7 trays.
- Step 3. 2 packs of moisture absorbers are to be placed on the top tray as shown in the drawing.  
Put piled trays into a sealing bag.  
Vacuum and seal the sealing bag with the vacuum sealing machine.
- Step 4. The stack of trays in the plastic back is to be inserted into a inner carton.
- Step 5. A corrugated board is to be placed on the top and on the bottom of the inner carton.  
The two corrugated boards and the inner carton is to be inserted into an outer carton.
- Step 6. The outer carton needs to sealed with packing tape as shown in the drawing.  
The model number, quantity of products, and shipping date are to be printed on the outer carton.  
If necessary, shipping labels or impression markings are to be put on the outer carton.
- Step 7. The outer carton is to be inserted into a extra outer carton with same direction.  
The extra outer carton needs to sealed with packing tape as shown in the drawing.
- Step 8. The model number, quantity of products, and shipping date are to be printed on the extra outer carton.  
If necessary, shipping labels or impression markings are to be put on the extra outer carton.

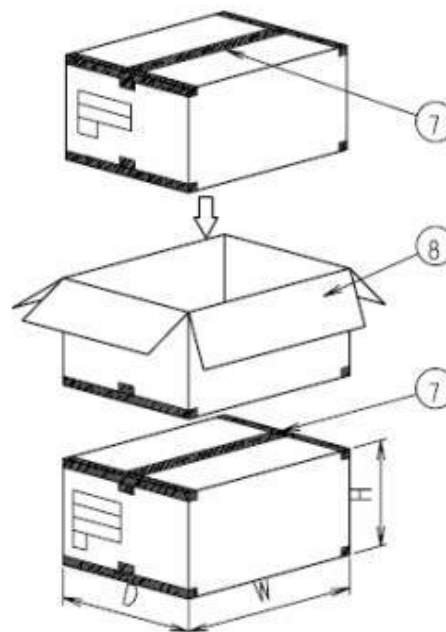

Remark: The return of packing materials is not required.

	Packing item name	Specs., Material
①	TRAY	A-PET
②	SEALING BAG	
③	INNER CARTON	Corrugated cardboard
④	INNER BOARD	Corrugated cardboard
⑤	OUTER CARTON	Corrugated cardboard
⑥	Drier	Moisture absorber
⑦	Packing tape	
⑧	EXTRA OUTER CARTON	Corrugated cardboard
⑨	FOAM SHEET	Anti-static polyethylene

Dimension of extra outer carton	
D : Approx.	(338mm)
W : Approx.	(549mm)
H : Approx.	(198mm)
Quantity of products in one carton:	4pcsx7=28pcs
Gross weight : Approx.	7.1Kg

## 14. Handling Instruction

## 14.1 Cautions for Handling LCD panels

**Caution**

- (1) Do not make an impact on the LCD panel glass because it may break and you may get injured from it.
- (2) If the glass breaks, do not touch it with bare hands.  
(Fragment of broken glass may stick you or you cut yourself on it.)
- (3) If you get injured, receive adequate first aid and consult a medial doctor.
- (4) Do not let liquid crystal get into your mouth.  
(If the LCD panel glass breaks, try not let liquid crystal get into your mouth even toxic property of liquid crystal has not been confirmed.)
- (5) If liquid crystal adheres, rinse it out thoroughly.  
(If liquid crystal adheres to your cloth or skin, wipe it off with rubbing alcohol or wash it thoroughly with soap. If liquid crystal gets into eyes, rinse it with clean water for at least 15 minutes and consult an eye doctor.)
- (6) If you scrap this products, follow a disposal standard of industrial waste that is legally valid in the community, country or territory where you reside.
- (7) Do not connect or disconnect this product while its application products is powered on.
- (8) Do not attempt to disassemble or modify this product as it is precision component.
- (9) If a part of soldering part has been exposed, and avoid contact (short-circuit) with a metallic part of the case etc. about FPC of this model, please.  
Please insulate it with the insulating tape etc. if necessary.  
The defective operation is caused, and there is a possibility to generation of heat and the ignition.
- (10) Since excess current protection circuit is not built in this TFT module, there is the possibility that LCD module or peripheral circuit become feverish and burned in case abnormal operation is generated.  
We recommend you to add excess current protection circuit to power supply.
- (11) The end part of glass and film of touch panel has conductivity, and avoid contact (short-circuit) with electroconductive case etc.. There is a possibility of setting up a defective touch panel, and insulate it for the case suppression (cushion etc.) if necessary, please.

**Caution**

**This mark is used to indicate a precaution or an instruction which, if not correctly observed, may result in bodily injury, or material damages alone.**

## 14.2 Precautions for Handling

- 1) Wear finger tips at incoming inspection and for handling the TFT monitors to keep display quality and keep the working area clean.  
Do not touch the surface of the monitor as it is easily scratched.
- 2) Wear grounded wrist-straps and use electrostatic neutralization blowers to prevent static charge and discharge when handling the TFT monitors as the LED in this TFT monitors is damageable to electrostatic discharge.  
Designate an appropriate operating area, and set equipment, tools, and machines properly when handling this product.
- 3) Avoid strong mechanical shock including knocking, hitting or dropping to the TFT monitors for protecting their glass parts. Do not use the TFT monitors that have been experienced dropping or strong mechanical shock.
- 4) Do not use or storage the TFT monitors at high temperature and high humidity environment. Particularly, never use or storage the TFT monitors at a location where condensation builds up.
- 5) Avoid using and storing TFT monitors at a location where they are exposed to direct sunlight or ultraviolet rays to prevent the LCD panels from deterioration by ultraviolet rays.
- 6) Do not stain or damage the contacts of the FPC cable .  
FPC cable needs to be inserted until it can reach to the end of connector slot.  
During insertion, make sure to keep the cable in a horizontal position to avoid an oblique insertion.  
Otherwise, it may cause poor contact or deteriorate reliability of the FPC cable.
- 7) Do not bend or pull the FPC cable or carry the TFT monitor by holding the FPC cable.
- 8) Peel off the protective film on the TFT monitors during mounting process.  
Refer to the section 14.5 on how to peel off the protective film.  
We are not responsible for electrostatic discharge failures or other defects occur when peeling off the protective film.

## 14.3 Precautions for Operation

- 1) Since this TFT monitors are not equipped with light shielding for the driver IC, do not expose the driver IC to strong lights during operation as it may cause functional failures.
- 2) In case of powering up or powering off this LCD module, be sure to comply the sequence as instructed in this specification.
- 3) Optimize VCOMDC within recommended operating conditions.  
\* When VCOMDC is not an optimal value, flicker and image sticking will be occurred.
- 4) Do not plug in or out the FPC cable while power supply is switch on.  
Plug the FPC cable in and out while power supply is switched off.
- 5) Do not operate the TFT monitors in the strong magnetic field. It may break the TFT monitors.
- 6) Do not display a fixed image on the screen for a long time.  
Use a screen-saver or other measures to avoid a fixed image displayed on the screen for a long time. Otherwise, it may cause burn-in image on the screen due the characteristics of liquid crystal.



#### 14.4 Storage Condition for Shipping Cartons

##### Storage environment

- Temperature 0 to 40° C
- Humidity 60%RH or less  
No-condensing occurs under low temperature with high humidity condition.
- Atmosphere No poisonous gas that can erode electronic components and/or wiring materials should be detected.
- Time period 3 months
- Unpacking To prevent damages caused by static electricity, anti-static precautionary measures (e.g. earthing, anti-static mat) should be implemented.
- Maximum piling up 7 cartons

#### 14.5 Precautions for Peeling off the Protective film

The followings work environment and work method are recommended to prevent the TFT monitors from static damage or adhesion of dust when peeling off the protective films.

##### A) Work Environment

- a) Humidity: 50 to 70 %RH, Temperature 15 to 27° C
- b) Operators should wear conductive shoes, conductive clothes, conductive finger tips and grounded wrist-straps. Anti-static treatment should be implemented to work area's floor.
- c) Use a room shielded against outside dust with sticky floor mat laid at the entrance to eliminate dirt.

##### B) Work Method

The following procedures should taken to prevent the driver ICs from charging and discharging.

- a) Use an electrostatic neutralization blower to blow air on the TFT monitors to its lower right when FPC cable placed down.  
Optimize direction of the blowing air and the distance between the TFT monitors and the electrostatic neutralization blower.
- b) Peel off the tab slowly (spending more than 2 secs to complete) by pulling it to opposite direction.

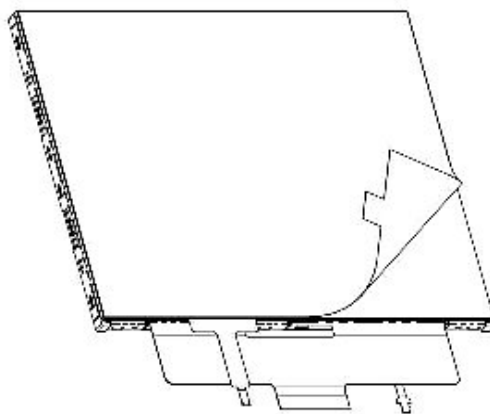

When FPC cable placed down.

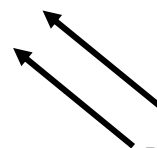

Direction of blowing air  
(Optimize air direction and the distance)

**APPENDIX**

Reference Method for Measuring Optical Characteristics and Performance

1. Measurement Condition (Backlight ON)

Measuring instruments: CS1000 (KONICA MINOLTA) , LCD7200(OTSUKA ELECTRONICS) ,EZcontrast160D (ELDIM)

Driving condition: Refer to the section "Optical Characteristics"

Measured temperature: 25° C unless specified

Measurement system: See the chart below. The luminance meter is placed on the normal line of measurement system.

Measurement point: At the center of the screen unless otherwise specified

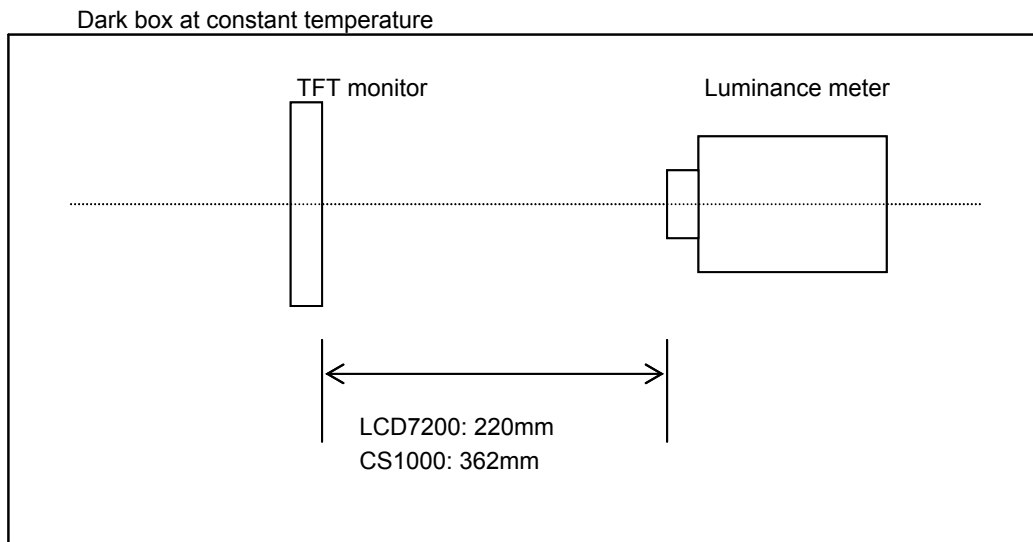

Measurement is made after 30 minutes of lighting of the backlight.

Measurement point: At the center point of the screen  
Brightness distribution: 9 points shown in the following drawing.

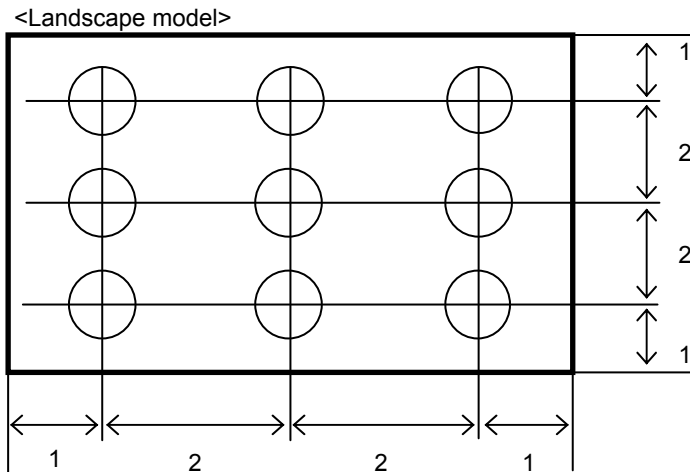

Dimensional ratio of active area

Backlight IL=10.2mA

Measurement Condition (Contrast ratio Backlight OFF only)

- Measuring instruments: LCD7200(OTSUKA ELECTRONICS),Ring Light(40,000 lx, $\phi$ 58)
- Driving condition: Refer to the section "Optical Characteristics"
- Measured temperature: 25° C unless specified
- Measurement system: See the chart below.
- Measurement point: At the center of the screen.

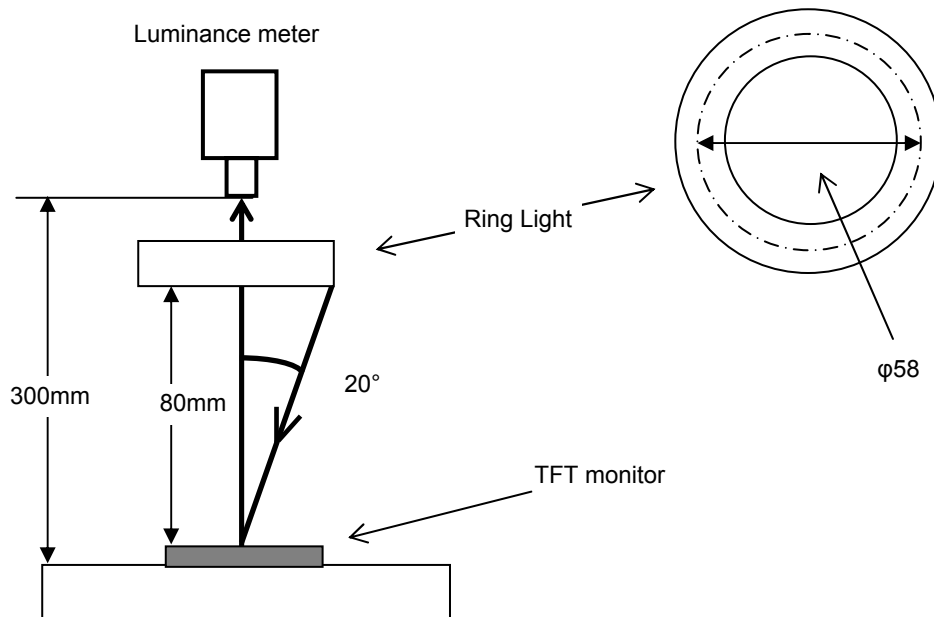

## 2. Test Method

Notice	Item	Test method	Measuring instrument	Remark
1	Response time	<p>Measure output signal waveform by the luminance meter when raster of window pattern is changed from white to black and from black to white.</p>	LCD7200	<p>Black display [Data]=00h White display [Data]=3Fh TON Rise time TOFF Fall time</p>
2	Contrast ratio	<p>Measure maximum luminance Y1([Data]=3Fh) and minimum luminance Y2([Data]=00h) at the center of the screen by displaying raster or window pattern. Then calculate the ratio between these two values.</p> <p>Contrast ratio = Y1/Y2</p> <p>Diameter of measuring point: 8mmφ(CS1000)</p> <p>Diameter of measuring point: 3mmφ(LCD7200)</p>	CS1000 LCD7200	Backlight ON Backlight OFF
3	Viewing angle Horizontalθ Verticalφ	Move the luminance meter from right to left and up and down and determine the angles where contrast ratio is 10.	EZcontrast160D	
5	White chromaticity	<p>Measure chromaticity coordinates x and y of CIE1931 colorimetric system at [Data] = 3Fh</p> <p>Color matching faction: 2°view</p>	CS1000	
6	Burn-in	Visually check burn-in image on the screen after 0.5 hours of "window display" ([Data]=3Fh/00h).		
7	Center brightness	Measure the brightness at the center of the screen.	CS1000	
8	Brightness distribution	<p>(Brightness distribution) = 100 x B/A %</p> <p>A : max. brightness of the 9 points</p> <p>B : min. brightness of the 9 points</p>	CS1000	

\* Linearity Measurement of Touch Panel

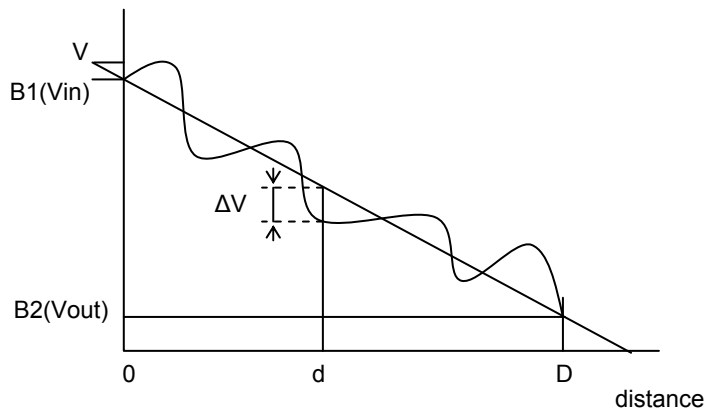

$$LE(\%) = \frac{\Delta V}{(V_{in} - V_{out})} \times 100$$

$$LE_{max}(\%) = \frac{\Delta V_{max}}{(V_{in} - V_{out})} \times 100$$

■ Cautionary instruction to handle a Touch-panel

● Cushion (between Touch Panel Chassis) Design

1) A cushion is required to be placed between Touch Panel and customer's chassis and there is a designated area to attach it. Attachment at area inside Input Prohibition Area must be forbidden.

If cushion was located inside Input Prohibition Area, Upper Electrode may be push constantly and which may cause the electrode breakage at the position falling on the edge of adhesive; it eventually results in Touch Panel malfunction in the future. (Please see "NG-1")

2) Be attention to the cushion material you use. In the case that too soft cushion was used, the cushion may protrude into Prohibition Area by being push strongly; which may result in the electrode breakage. Eventually there is a chance that the electrode breakage leads to the malfunction of Touch Panel in the future. (Please see "NG-2")

3) Cushion is required to be attached at the side of Customer's chassis.

Attaching a cushion at the side of Upper Electrode Film has a chance to deform the film and lead to the malfunction of Touch Panel in the future.

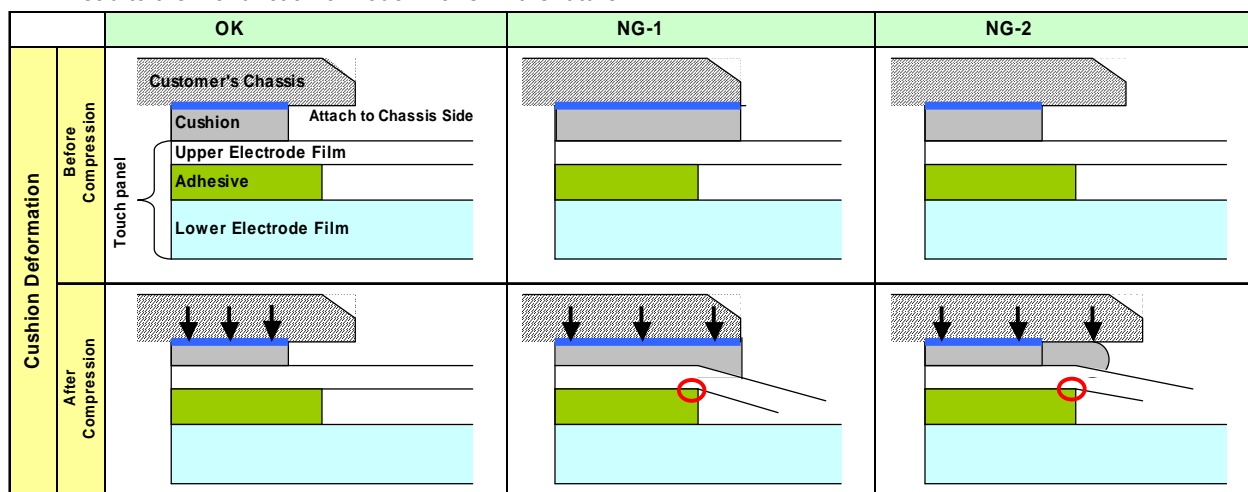

● Design Guidance of Chassis (Front Part)

4) Be attention to stay Input Prohibition Area away from touching and/or drawing by a stylus pens in order to avoid the electrode breakage and potential malfunction of Touch Panel. (Please see "NG-3")

We recommend customers to design chassis (front case) being able to protect Input Prohibition Area.

5) Clearance between customer's chassis and Touch Panel surface is certainly required in order to avoid erroneous input caused by a collision of the edge of chassis. (Please see "NG-4")

A clearance of 0.3 to 0.7mm is recommended.

● Design Guidance of Chassis (Side Part)

6) Upper Electrode and Lower Electrode fall on the edge of Touch Panel outline.

Redundant design having enough clearance to avoid electric short with chassis is highly recommended. (Please see "NG-5")

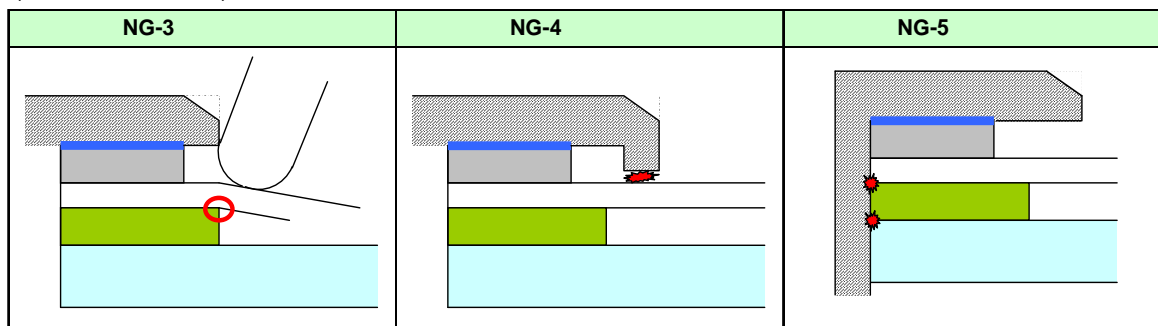

● Example of Recommended Chassis Design

Refer to "3.2 Outward Form".

● As a terminal resistance has individual specificity, calibration to align the displaying and the sensing position one each is mandatory before use.