

Specifications for Blanview TFT-LCD Monitor

Version 1.0

(Please be sure to check the specifications latest version.)

MODEL COM35H3N99XTC

Customer's Approval
Signature:
Name:
Section:
Title:
Date:

ORTUSTECH

ORTUS TECHNOLOGY CO., LTD.

Approved by

M. Sugatani

Approved by

H. Mori

Checked by

O. Shimura

Prepared by

M. Ito

Contents

1.	APPLICATION	4
2.	OUTLINE SPECIFICATIONS		
	2.1 Features of the Products	5
	2.2 Display Method	5
3.	DIMENSIONS AND SHAPE		
	3.1 Dimensions	7
	3.2 Outward Form	8
	3.3 Serial Label (S-Label)	10
4.	PIN ASSIGNMENT	11
5.	ABSOLUTE MAXIMUM RATING	12
6.	RECOMMENDED OPERATING CONDITIONS	12
7.	CHARACTERISTICS		
	7.1 DC Characteristics	13
	7.2 AC Characteristics	14
8.	Input Timing		
	8.1 Input Timing Characteristics	16
	8.2 Driving Timing Chart	17
	8.3 Example of Driving Timing Chart	18
	8.4 Power ON/OFF sequence	19
	8.5 Display ON/OFF sequence	20
	8.6 Reset sequence	20
9.	CIRCUIT		
	9.1 Touch Panel Circuit	21
	9.2 LED Circuit	21
10.	CHARACTERISTICS		
	10.1 Optical Characteristics	22
	10.2 Temperature Characteristics	23
11.	CRITERIA OF JUDGMENT		
	11.1 Defective Display and Screen Quality	24
	11.2 Screen and Other Appearance	25
12.	RELIABILITY TEST	26
13.	PACKING SPECIFICATIONS	28
14.	HANDLING INSTRUCTION		
	14.1 Cautions for Handling LCD panels	29
	14.2 Precautions for Handling	30
	14.3 Precautions for Operation	30
	14.4 Storage Condition for Shipping Cartons	31
	14.5 Precautions for Peeling off the Protective film	31
	APPENDIX	32

1. APPLICATION

This Specification is applicable to 8.94cm (3.5 inch) Blanview TFT-LCD back-light monitor for non-military use.

- ⊙ ORTUS TECHNOLOGY makes no warranty or assume no liability that use of this Product and/or any information including drawings in this Specification by Purchaser is not infringing any patent or other intellectual property rights owned by third parties, and ORTUS TECHNOLOGY shall not grant to Purchaser any right to use any patent or other intellectual property rights owned by third parties. Since this Specification contains ORTUS TECHNOLOGY'S confidential information and copy right, Purchaser shall use them with high degree of care to prevent any unauthorized use, disclosure, duplication, publication or dissemination of ORTUS TECHNOLOGY'S confidential information and copy right.
- ⊙ If Purchaser intends to use this Products for an application which requires higher level of reliability and/or safety in functionality and/or accuracy such as transport equipment (aircraft, train, automobile, etc.), disaster-prevention/security equipment or various safety equipment, Purchaser shall consult ORTUS TECHNOLOGY on such use in advance.
- ⊙ This Product shall not be used for application which requires extremely higher level of reliability and/or safety such as aerospace equipment, telecommunication equipment for trunk lines, control equipment for nuclear facilities or life-support medical equipment.
- ⊙ It must be noted as an mechanical design manner, especial attention in housing design to prevent arcuation/flexure or caused by stress to the LCD module shall be considered.
- ⊙ ORTUS TECHNOLOGY assumes no liability for any damage resulting from misuse, abuse, and/or miss-operation of the Product deviating from the operating conditions and precautions described in the Specification.
- ⊙ ORTUS TECHNOLOGY is not responsible for any nonconformities and defects that are not specified in this specifications.
- ⊙ If any issue arises as to information provided in this Specification or any other information, ORTUS TECHNOLOGY and Purchaser shall discuss them in good faith and seek solution.
- ⊙ ORTUS TECHNOLOGY assumes no liability for defects such as electrostatic discharge failure occurred during peeling off the protective film or Purchaser's assembly process.
- ⊙ This Product is compatible for RoHS directive.

Object substance	Maximum content [ppm]
Cadmium and its compound	100
Hexavalent Chromium Compound	1000
Lead & Lead compound	1000
Mercury & Mercury compound	1000
Polybrominated biphenyl series (PBB series)	1000
Polybrominated biphenyl ether series (PBDE series)	1000

2. OUTLINE SPECIFICATIONS

2.1 Features of the Product

- 3.5" diagonal with resolution of 720[H]x320[V] dots.
- 6-bit 262,144 color display capability.
- Single power supply operation of 3V.
- Timing generator (TG), Counter-electrode driving circuitry, Built-in power supply circuit.
- Long life & High brightness LED back-light and Touch panel operation monitor.
- Blanview TFT-LCD, improved outdoor readability.

	Indoor		Outdoor	
	Readability	Power Efficiency (Battery Life)	Readability	Power Efficiency (Battery Life)
Transmissive	Good	Good	Fair	Poor
Transflective	Fair	Poor	Good	Good
Blanview	Good	Good	Good	Good

2.2 Display Method

Items	Specifications	Remarks
Display type	TN type 262,144 Colors. Blanview, Normally white.	
Driving method	a-Si TFT Active matrix. Line-scanning, Non-interlace.	
Dot arrangement	RGB stripe arrangement.	Refer to Fig. 1
Input signal type	6-bit RGB, parallel input.	
Backlight	Long life & High bright white LED.	
Touch panel	Resistance type, transmissive analog tablet	

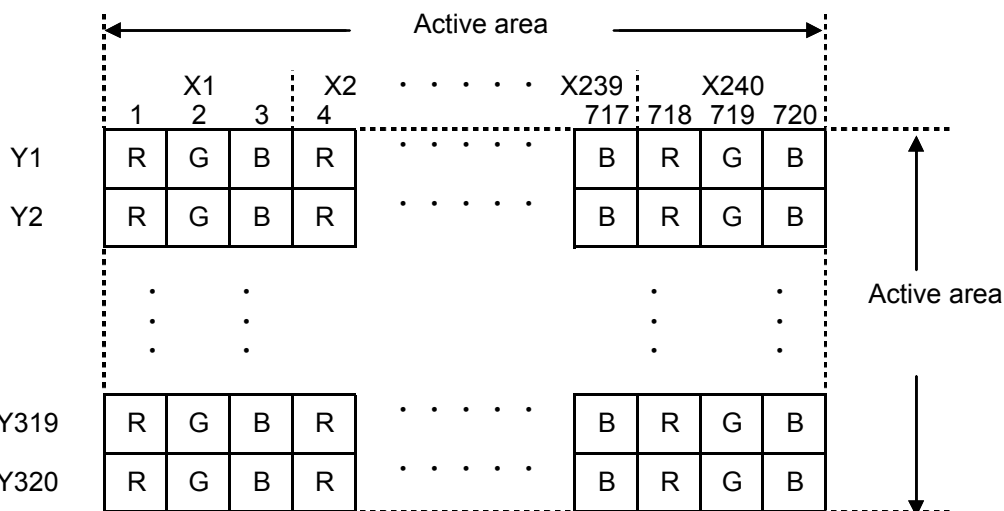
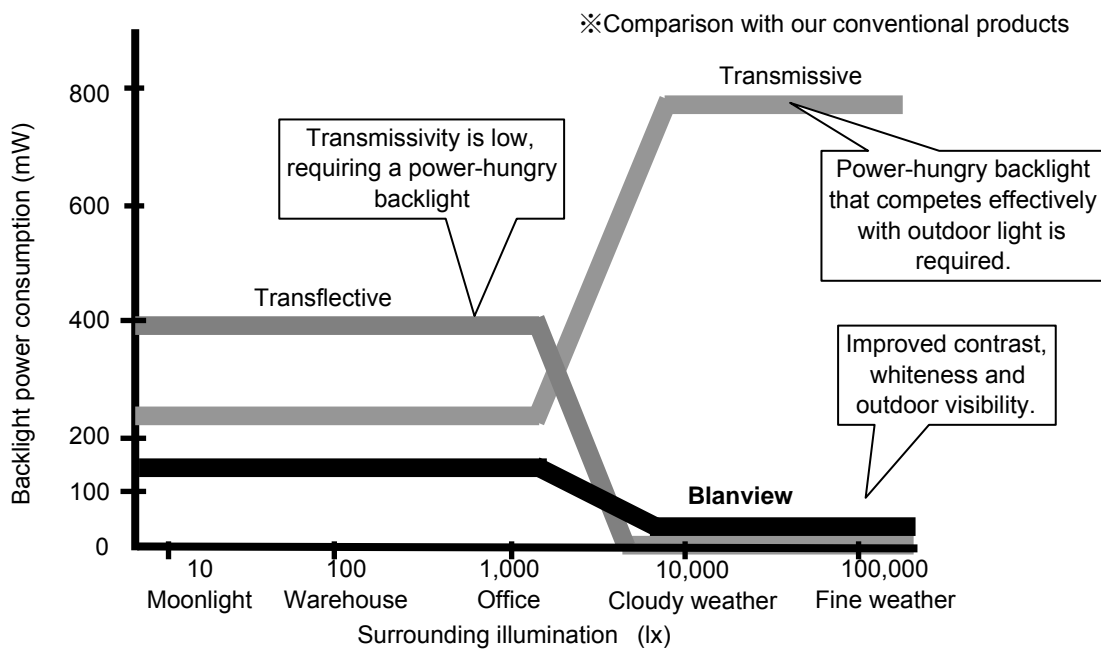

Fig. 1 Dot arrangement (FPC cable placed leftside)

Features of Blanview

Backlight power consumption required to assure visibility (equivalent to 3.5"QVGA.)



Contrast characteristics under 100,000lx (same condition as direct sunlight.)

With better contrast (higher contrast ratio), Blanview TFT-LCD has the best outdoor readability in three different types of TFT-LCD.

Below chart shows contrast value against panel surface brightness. (Horizontal: Panel surface brightness/ Vertical: Contrast value) LCD panel has enough outdoor readability above our Standard line. (ORTUS TECHNOLOGY criteria)

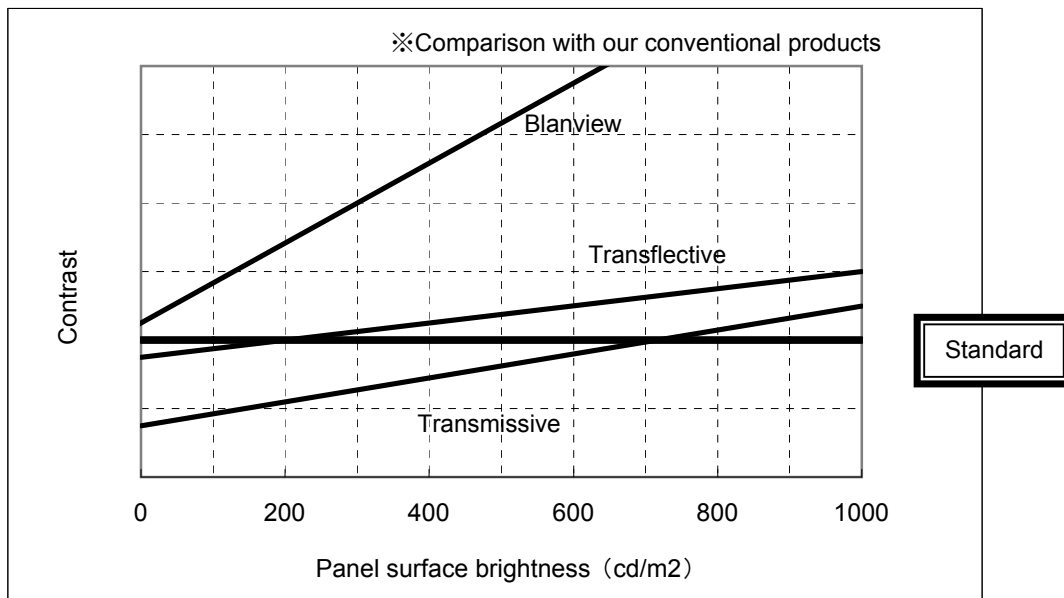

3. DIMENSIONS AND SHAPE

3.1 Dimensions

Items	Specifications	Unit	Remarks
Outline dimensions	63.50[H] × 85.00[V] × 4.33[D]	mm	Exclude FPC cable and parts on FPC.
Active area	53.64[H]×71.52[V]	mm	8.94cm diagonal
Number of dots	720[H]×320[V]	dot	
Dot pitch	74.5[H]×223.5[V]	μm	
Hardness of Touch Panel surface	3	H	Load: 4.9N
Weight	43.5	g	Include FPC cable

3.2 Outward Form

(8/36)
14TLM101
Issue: May. 29, 2015

EC No.	REV.No.	REVISE	DATE (Y:M:D)	APPROVED	CHECKED	PREPARED
--------	---------	--------	--------------	----------	---------	----------

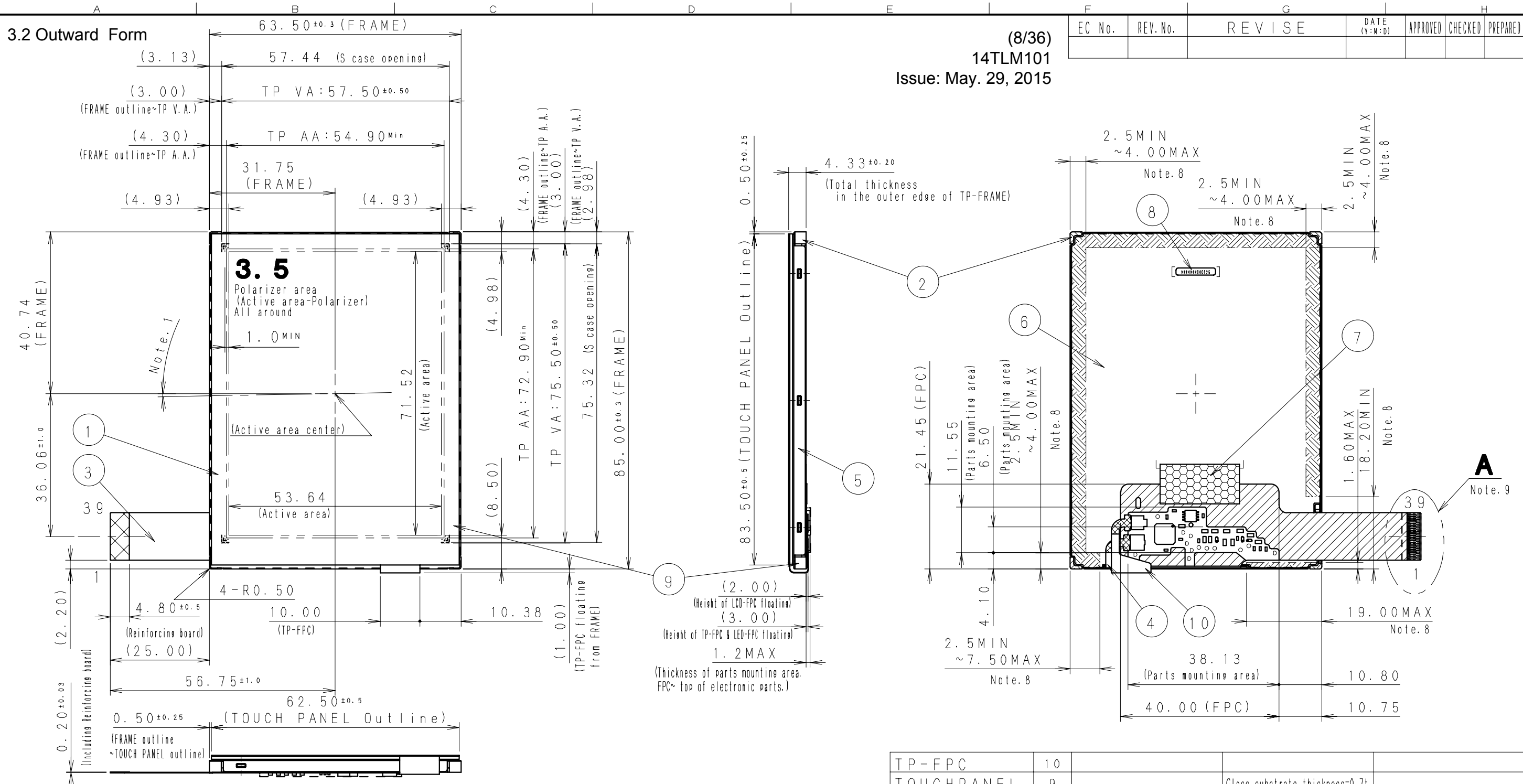

- Note 1. Angular deviation of LCD cell from the TFT-LCD monitor's reference axis shall be less than $[\pm 40']$.
- Note 2. S label is affixed the area shown in the drawing. The thickness of the S label will be added to that of S case's surface.
- Note 3. Recommended FPC connectors
For LCD : HIROSE, part number: FH23-39S-0.3SHW (05)
- Note 4. Protective film is affixed on front surface of the screen. Location tolerance of the protective film shall be ± 1.5 mm to the polarizing film.
- Note 5. Keep a gap, for example 0.3 to 0.7mm between the bezel edge and T/P surface to avoid the bezel edge from making contacting with the T/P surface that may cause a "false touch" with the bottom layer.
- Note 6. Bezel Opening design:
It is recommended to design based on LCD Active area and LCD Active area center. Please place the bezel opening to maintain the operation by a stylus pen or finger inside the T/P response area. (Refer to "Example of housing design")
The dimensions shown (note6) in drawing are One example of the bezel design.
- Note 7. Linearity is guaranteed in the area surrounded by 3mm inside lines from TOUCHPANEL Active Area.
- Note 8. In case TFT-LCD monitor is fixed to the case of your product, it's recommended that monitor is fixed in to area.
- Note 9. Refer to "4. PIN ASSIGNMENT" about the pin No. of TOUCHPANEL.
- Note 10. Refer to "11. CRITERIA OF JUDGMENT" about the appearance specification of a polarizer.

TP-FPC	10		
TOUCHPANEL	9		Glass substrate thickness=0.7t
S LABEL	8		t = 0.075
I-TAPE	7		t = 0.05
S CASE C	6	SUS304	
S CASE A	5	SUS304	
LED-FPC	4		
LCD-FPC	3		
FRAME	2	PC	
LCD	1		Glass substrate thickness=0.5t

PART NAME	ITEM	MATERIAL GRADE	REMARK
APPROVED 橋爪	GENERAL TOLERANCE ± 0.5	SCALE 1/1	UNIT mm
CHECKED 平信	ISSUE (Y:M:D) 15:05:20	MODEL COM35H3N99X**	ORTUSTECH ORTUS TECHNOLOGY CO., LTD. DO NOT DUPLICATE, CONFIDENTIAL AND PROPRIETARY
CHECKED	NAME		
DESIGN 小林宣幸	OUTLINE-D3N99		DRAWING No. RJD527028D301
DRAW 小林宣幸			REV. SHEET DIV. 1/2

(9/36)
14TLM101
Issue: May. 29, 2015

EC No.	REV.No.	REVISE	DATE (Y:M:D)	APPROVED	CHECKED	PREPARED

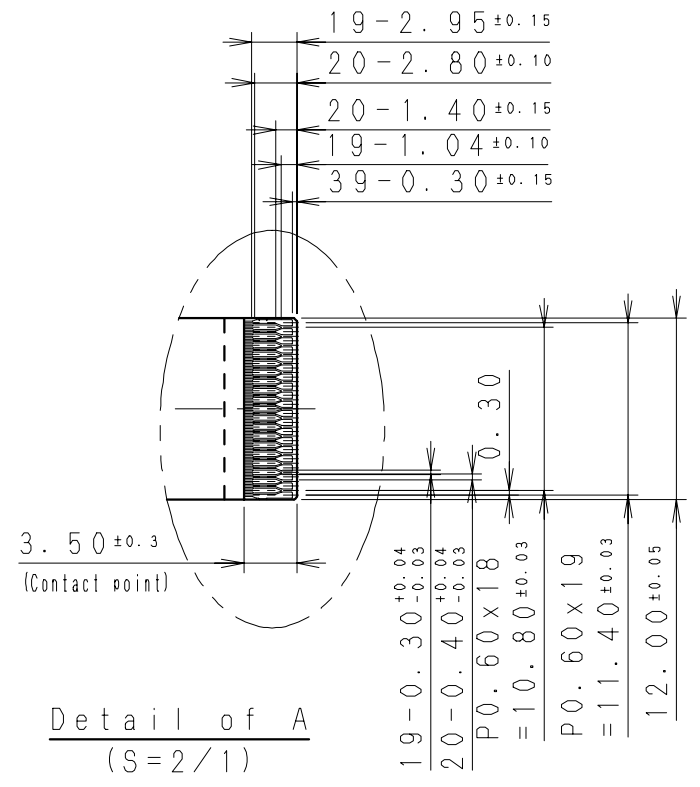

Example of Housing Design

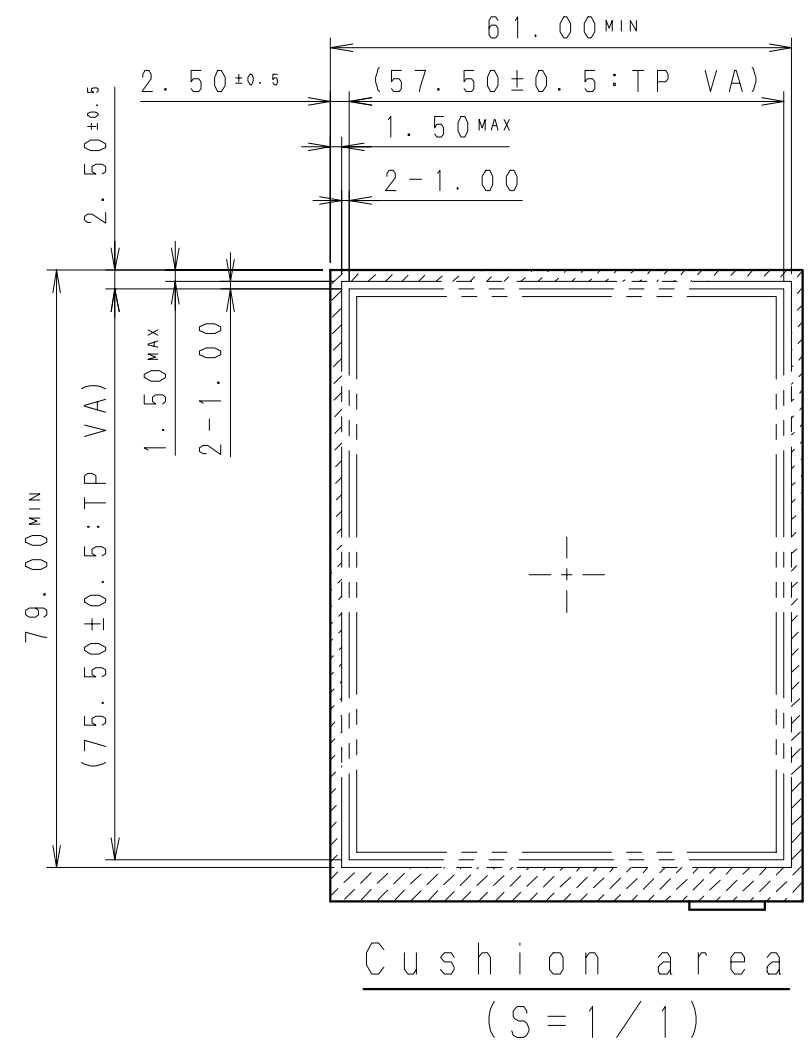
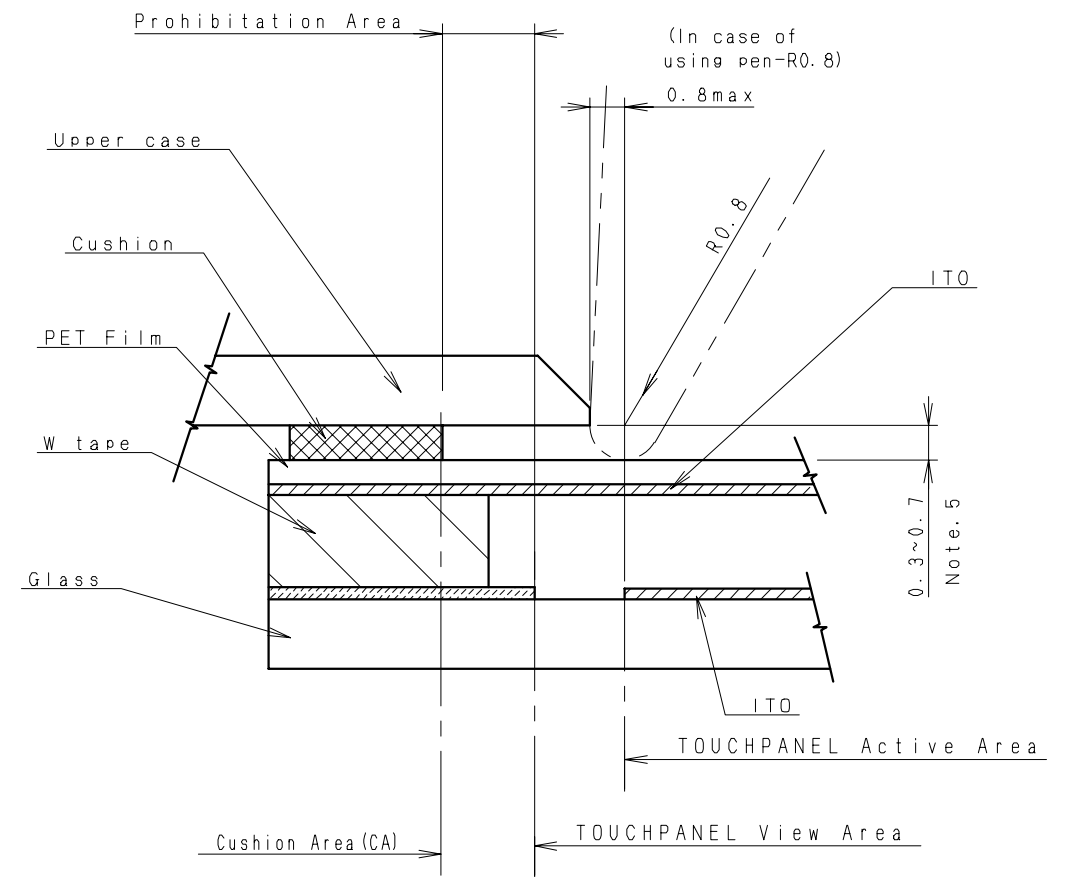

Design guidance for the upper case & the cushion

- Note 11. Upper case opening
- a. Please place the upper case opening to maintain the operation by a stylus pen inside the TP response area
 - b. The any pressures in the area between TP response area and TP viewing area is prohibited.
 - c. Please use the appropriate material (PMMA, PC, etc.) as the upper case.
- Note 12. Cushion design
- a. Please put the cushion on the upper case.
 - b. Do not use an adhesive tape to stick on the TP surface.
 - c. Please position the cushion over the cushion area to avoid a short.

APPROVED 橋爪	GENERAL TOLERANCE ±0.5	SCALE FREE	UNIT mm	ORTUSTECH ORTUS TECHNOLOGY CO., LTD. DO NOT DUPLICATE, CONFIDENTIAL AND PROPRIETARY	
CHECKED 平信	ISSUE (Y:M:D) 15:05:20	MODEL COM35H3N99X**			
CHECKED	NAME	OUTLINE-D3N99		DRAWING No.	
DESIGN 荒川晴久				REV.	SHEET
DRAW 荒川晴久				2/2	DIV.
				RJD527028D301	

3.3 Serial Label (S-Label)

1) Display Items

S-label indicates the least significant digit of manufacture year (1 digit), manufacture month with below alphabet (1 letter), model code (5 characters), serial number (6 digits).

* Contents of Display

*	*	*****	*****
—	—	—	—
a	b	c	d

Contents of display																	
a	The least significant digit of manufacture year																
b	<table style="width: 100%; border-collapse: collapse;"> <tr> <td style="width: 25%;">Jan-A</td> <td style="width: 25%;">May-E</td> <td style="width: 25%;">Sep-I</td> <td style="width: 25%;"> </td> </tr> <tr> <td>Feb-B</td> <td>Jun-F</td> <td>Oct-J</td> <td> </td> </tr> <tr> <td>Mar-C</td> <td>Jul-G</td> <td>Nov-K</td> <td> </td> </tr> <tr> <td>Apr-D</td> <td>Aug-H</td> <td>Dec-L</td> <td> </td> </tr> </table>	Jan-A	May-E	Sep-I		Feb-B	Jun-F	Oct-J		Mar-C	Jul-G	Nov-K		Apr-D	Aug-H	Dec-L	
Jan-A	May-E	Sep-I															
Feb-B	Jun-F	Oct-J															
Mar-C	Jul-G	Nov-K															
Apr-D	Aug-H	Dec-L															
c	<table style="width: 100%; border-collapse: collapse;"> <tr> <td style="width: 25%;">Model code</td> <td>35MNC (Made in Japan)</td> </tr> <tr> <td></td> <td>35MPC (Made in Malaysia)</td> </tr> </table>	Model code	35MNC (Made in Japan)		35MPC (Made in Malaysia)												
Model code	35MNC (Made in Japan)																
	35MPC (Made in Malaysia)																
d	Serial number																

* Example of indication of Serial label (S-label)

- Made in Japan

5K35MNC000125

means "manufactured in November 2015, 3.5" MN type, C specifications, serial number 000125"

- Made in Malaysia

5K35MPC000125

means "manufactured in November 2015, 3.5" MP type, C specifications, serial number 000125"

2) Location of Serial Label (S-label)

Refer to "3.2 Outward Form".

4. PIN ASSIGNMENT

No.	Symbol	Functions
1	VSS	Ground
2	VSS	Ground
3	VDD	Power supply
4	VDD	Power supply
5	VSS	Ground
6	RESETB	Reset signal. When RESETB is Lo, an internal reset is performed.
7	HSYNC	Horizontal sync signal input. (Low active)
8	VSYNC	Vertical sync signal input. (Low active)
9	CLK	Clock signal for data latching and internal counter of the timing controller
10	VSS	Ground
11	D00	Display data(B) 00h: Black D00:LSB D05:MSB Driver has internal gamma conversion.
12	D01	
13	D02	
14	D03	
15	D04	
16	D05	
17	D10	Display data(G) 00h: Black D10:LSB D15:MSB Driver has internal gamma conversion.
18	D11	
19	D12	
20	D13	
21	D14	
22	D15	
23	D20	Display data(R) 00h: Black D20:LSB D25:MSB Driver has internal gamma conversion.
24	D21	
25	D22	
26	D23	
27	D24	
28	D25	
29	VSS	Ground
30	DE	Input data effective signal. (It is effective for the period of "H")
31	STBYB	Standby signal (Hi:Normal operation, Lo:Standby operation)
32	TEST1	Connect to Ground.
33	XL	X-axis left terminal
34	YD	Y-axis downside terminal
35	XR	X-axis right terminal
36	YU	Y-axis upside terminal
37	TEST2	Connect to Ground.
38	BLH	LED drive power source (Anode side)
39	BLL	LED drive power source (Cathode side)

- Recommended connector: HIROSE ELECTRIC FH23 series [FH23-39S-0.3SHW(05)]
- Since FPC cable has gold plated terminals, gilt finish contact shoe connector is recommended.
- Please refer to the section 3.2 "Outward Form" for pin assignment.

5. ABSOLUTE MAXIMUM RATING

VSS=0V

Item	Symbol	Condition	Rating		Unit	Applicable terminal
			MIN	MAX		
Supply voltage	VDD	Ta=25°C	-0.3	4.6	V	VDD
Input voltage for logic	VI		-0.3	VDD+0.3	V	CLK, VSYNC, HSYNC, DE, D[05:00], D[15:10], D[25:20], STBYB, RESETB, TEST1, TEST2
LED forward current	IL	Ta = 25°C	—	35	mA	BLH - BLL
		Ta = 70°C	—	15		
Touch Panel input voltage	VIT		—	7.0	V	XL, YD, XR, YU
Storage temperature range	Tstg		-30	80	°C	
Storage humidity range	Hstg		Non condensing in an environmental moisture at or less than 40°C90%RH			

6. RECOMMENDED OPERATING CONDITIONS

VSS=0V

Item	Symbol	Condition	Rating			Unit	Applicable terminal
			MIN	TYP	MAX		
Supply voltage	VDD		2.7	3.0	3.6	V	VDD
Input voltage for logic	VI		0	—	VDD	V	CLK, VSYNC, HSYNC, DE, D[05:00], D[15:10], D[25:20], STBYB, RESETB, TEST1, TEST2
Operational temperature range Note 1	Top	Note 2	-20	+25	+70	°C	Touch panel surface temperature
Operating humidity range	Hop	Ta ≤ 30°C	20	—	80	%	
		Ta > 30°C	Non condensing in an environmental moisture at or less than 30°C80%RH.				

Note 1: This monitor is operable in this temperature range. With regard to optical characteristics, refer to the section 10 "Characteristics".

Note 2: Acceptable Forward Current to LED is up to 15mA, when Ta=+70°C.
Do not exceed Allowable Forward Current shown on the chart below (Fig. 2).

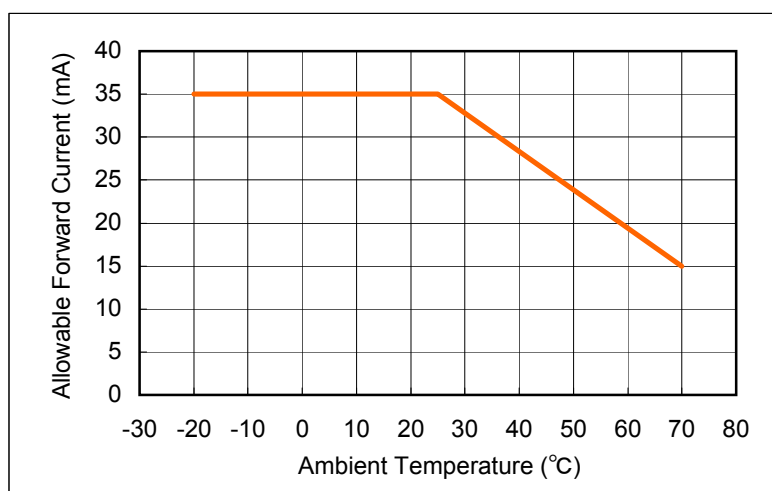

Fig. 2: Allowable Forward Current

7. CHARACTERISTICS

7.1 Electrical Characteristics

7.1.1 Display Module

(Unless otherwise noted, Ta=25°C, VDD=3.0V, VSS=0V)

Item	Symbol	Condition	Rating			Unit	Applicable terminals
			MIN	TYP	MAX		
Input voltage for logic	VIH		0.7×VDD	—	VDD	V	CLK, VSYNC, HSYNC DE, STBYB, RESETB D[05:00], D[15:10], D[25:20] TEST1, TEST2
	VIL		0	—	0.3×VDD	V	
Operating Current	IDD	fCLK=6.25MHz Color bar display	—	6.8	13.6	mA	VDD

7.1.2 Backlight

Item	Symbol	Condition	Rating			Unit	Applicable terminal
			MIN	TYP	MAX		
Forward current	IL25	Ta=25°C	—	6.5	35.0	mA	BLH - BLL
	IL70	Ta=70°C	—	—	15.0	mA	
Forward voltage	VL	Ta=25°C, IL=6.5mA	—	16.0	16.7	V	
Estimated Life of LED	LL	Ta=25°C, IL=6.5mA Note1	—	(50,000)	—	hr	

- Note1: - The lifetime of the LED is defined as a period till the brightness of the LED decreases to the half of its initial value.
- This figure is given as a reference purpose only, and not as a guarantee.
 - This figure is estimated for an LED operating alone.
- As the performance of an LED may differ when assembled as a monitor together with a TFT panel due to different environmental temperature.
- Estimated lifetime could vary on a different temperature and usually higher temperature could reduce the life significantly.

7.1.3 Touch Panel

Ta=25°C

Item	Symbol	Condition	Rating			Unit	Applicable terminals
			MIN	TYP	MAX		
Linearity	LE	3mm in surroundings Note is excluded	-1.5	—	+1.5	%	
Insulation resistance	RI	DC 25V	20	—	—	MΩ	XL, XR — YD, YU
Terminal resistance		X	200	—	900	Ω	XL, XR
		Y	200	—	900		YD, YU
Rated voltage on/off		DC	—	5	7	V	XL, YD, XR, YU
chattering		R 0.8mm Polyacetal pen	—	—	10	ms	XL, YD, XR, YU

Note: Linearity Measurement: Refer to the APPENDIX of "Reference Method for Measuring Optical Characteristics".
Load: 2.45N

Mechanical Reliability

Item	Rating			Unit	Remark
	MIN	TYP	MAX		
Detectable activation force	0.05	—	0.80	N	R0.8mm Polyacetal pen or finger Resistance between X and Y axis must be equal or lower than 2KΩ.
Keystroke durability	1,000,000	—	—	times	key the same part by silicon rubber (Touch Panel Active area only) •Rubber tip part: R8mm •Load: 2.50N •speed: 2 times/second

7.2 AC Characteristics

(Unless otherwise noted, Ta=25°C, VDD=3.0V, VSS=0V)

Item	Symbol	Condition	Rating			Unit	Applicable terminal
			MIN	TYP	MAX		
Clock frequency	fCLK		4.4	5.6	7.0	MHz	CLK
Clock Low period	tw1L	0.3×VDD or shorter	15	—	—	ns	CLK
Clock High period	tw1H	0.7×VDD or longer	15	—	—	ns	CLK
INPUT setup time	tsp		15	—	—	ns	CLK, VSYNC, HSYNC DE, D[05:00], STBYB
INPUT hold time	thd		15	—	—	ns	D[15:10], D[25:20]

Switching Characteristics Wave Form

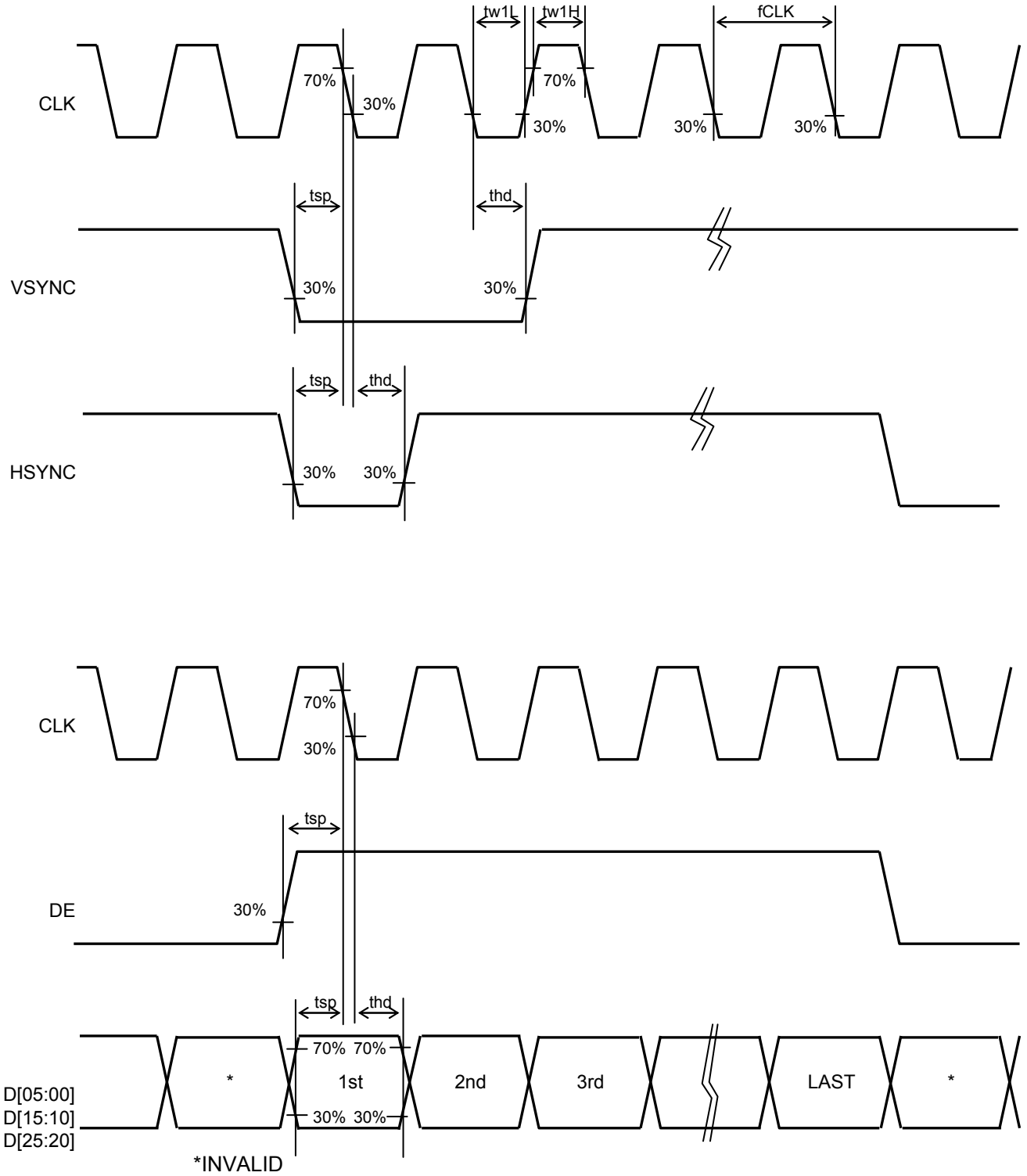

8. Input Timing

8.1 Input Timing Characteristics

(Unless otherwise noted, Ta=25°C, VDD=3.0V, VSS=0V)

Item	Symbol	Rating			Unit	Applicable terminals
		MIN	TYP	MAX		
CLK frequency	fCLK	4.4	5.6	7.0	MHz	CLK
VSYNC frequency	fVSYNC	54	60	66	Hz	VSYNC
VSYNC signal cycle time	tv	324	325	348	H	VSYNC,HSYNC
VSYNC pulse width	tw2H	1	—	—	H	VSYNC,HSYNC
Vertical back porch	tvb	2	—	14	H	VSYNC,HSYNC,DE D[05:00],D[15:10],D[25:20]
Vertical display period	tvdp	—	320	—	H	VSYNC,HSYNC,DE D[05:00],D[15:10],D[25:20]
HSYNC frequency	fHSYNC	—	19.5	—	kHz	HSYNC
HSYNC signal cycle time	th	—	287	402	CLK	HSYNC,CLK
HSYNC pulse width	tw3H	1	—	—	CLK	HSYNC,CLK
Horizontal back porch	thb	2	—	14	CLK	CLK,HSYNC,DE D[05:00],D[15:10],D[25:20]
DE pulse width	tw4H	—	240	—	CLK	DE,CLK
Horizontal display period	thdp	—	240	—	CLK	CLK,DE D[05:00],D[15:10],D[25:20]

Note 1: The characteristic of this item is recommended standard.
Please use it after it confirms it enough like the display fineness etc.
when it comes off from this characteristic and it is used.

8.2 Input Timing Chart

I. Vertical Timing

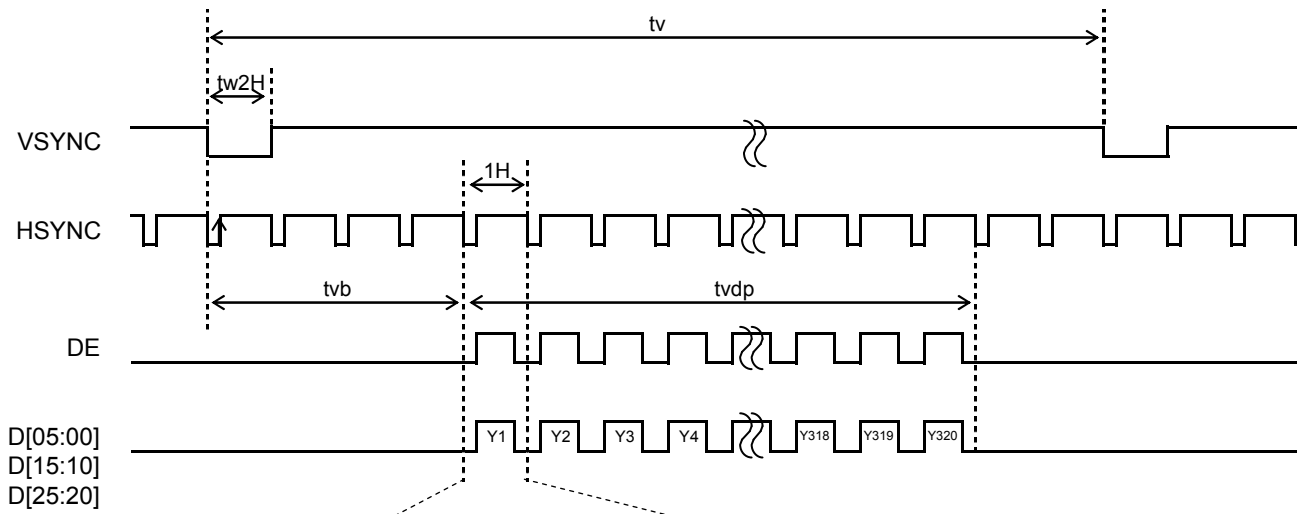

II. Horizontal Timing

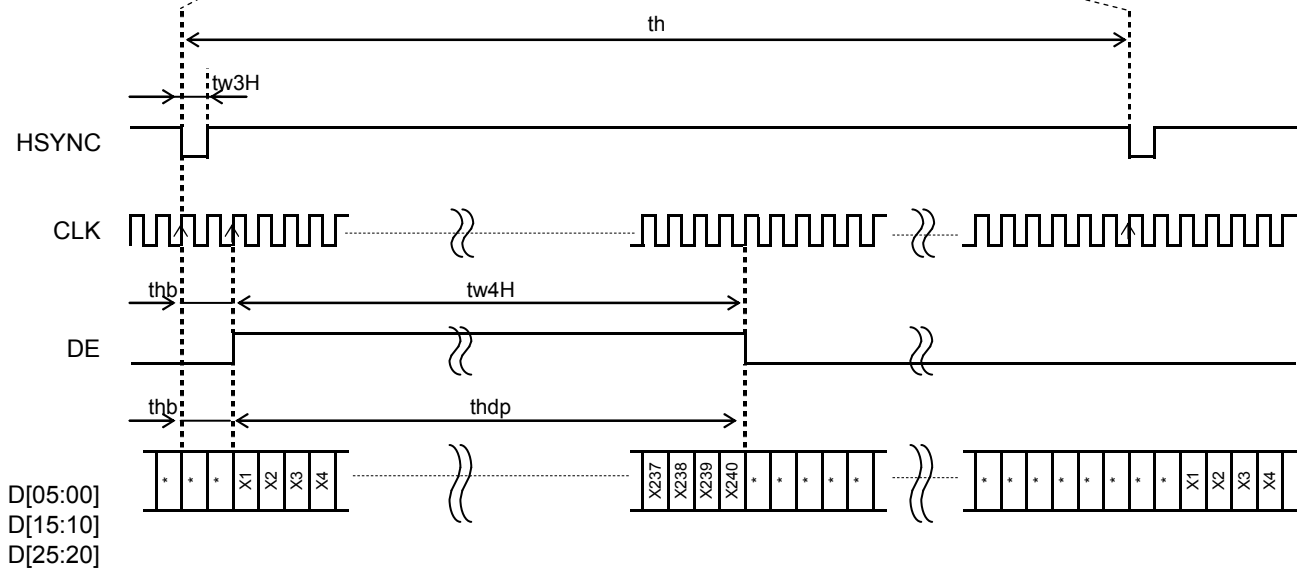

8.3 Example of Input Timing Chart (fCLK=5.0MHz, 5.6MHz, 6.25MHz)

I. Vertical Timing

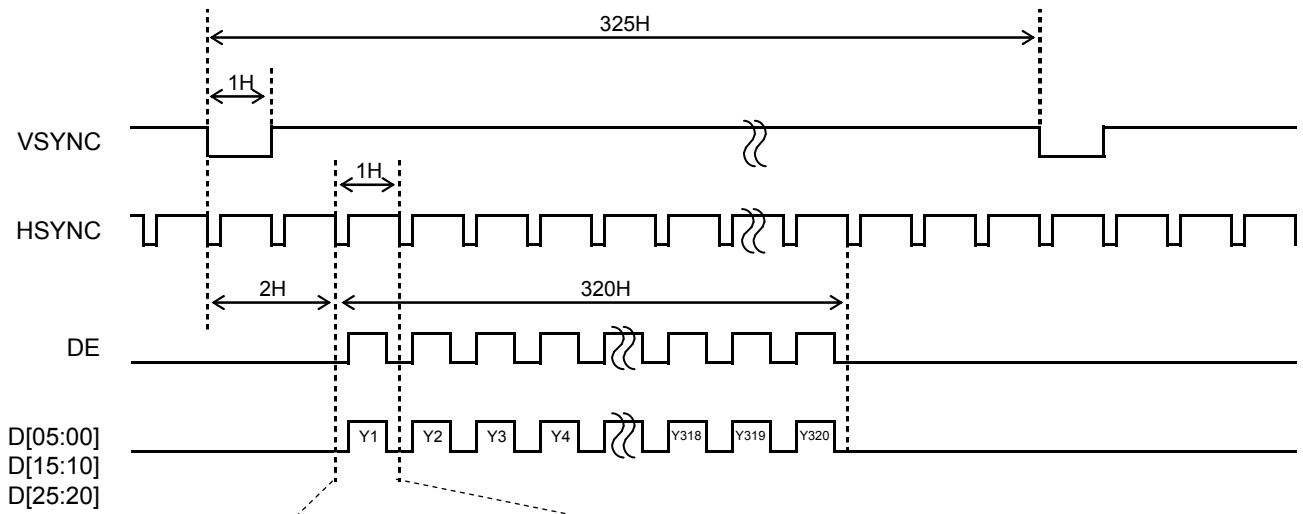

II. Horizontal Timing

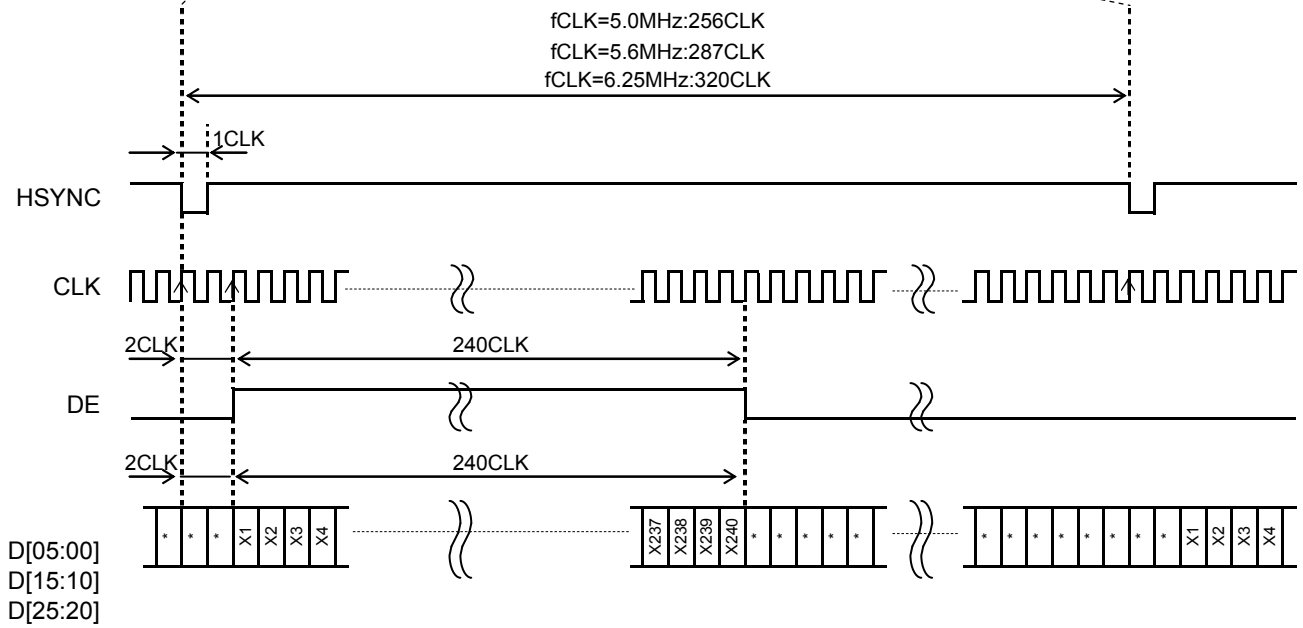

8.4 Power ON/OFF sequence

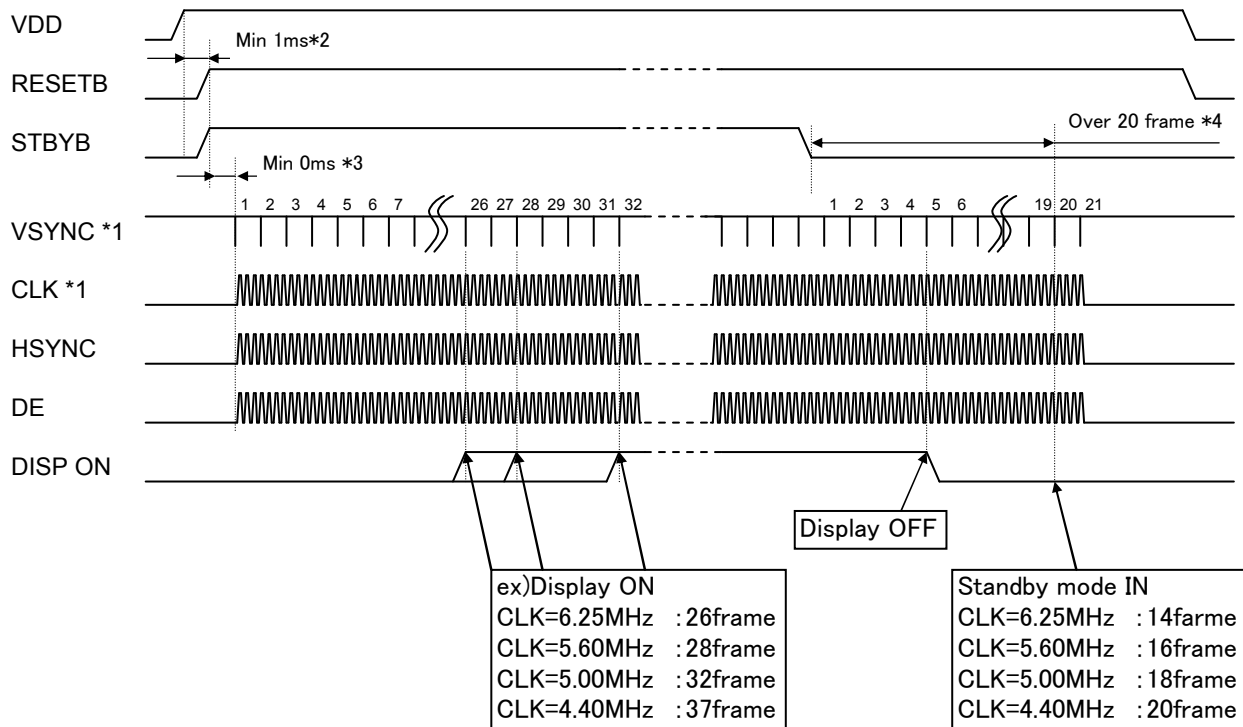

- *1 DOTCLK is used for Gate array CLK on FPC.
 VSYNC is used for Gate array's inside counter.
 It becomes the operation after CLK(DOTCLK),VSYNC input.
- *2 After the power supply,Please excute RESETB.(8.3 Reset sequence Reference)
- *3 There is no regulations at time until each signal is supplied from RESETB"H"
 But meanwhile, It is necessary to fix each signal to "H"or"L".
- *4 It is necessary to supply VSYNC and CLK(DOTCLK) for 20 frames or less from STBYB "L" to turning off the power supply without leaving the afterimage.

8.5 Display ON/OFF Sequence

It explains the display sequence when display ON/OFF by the STBYB signal. The following time will be needed according to the CLK cycle by the time the displays begun from the standby release.

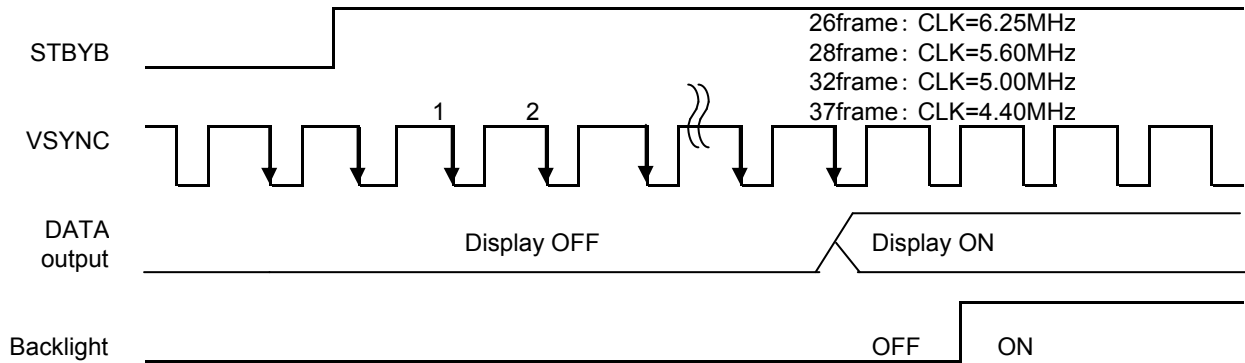

The following time will be needed according to the CLK cycle by the time the standby sequence is ended from the standby setting. Meanwhile, DOTCLK and the VSYNC signal should keep being supplied. When DOTCLK and the VSYNC signal are stopped or the power supply is turned off to a regulated frame or less, the afterimage might remain.

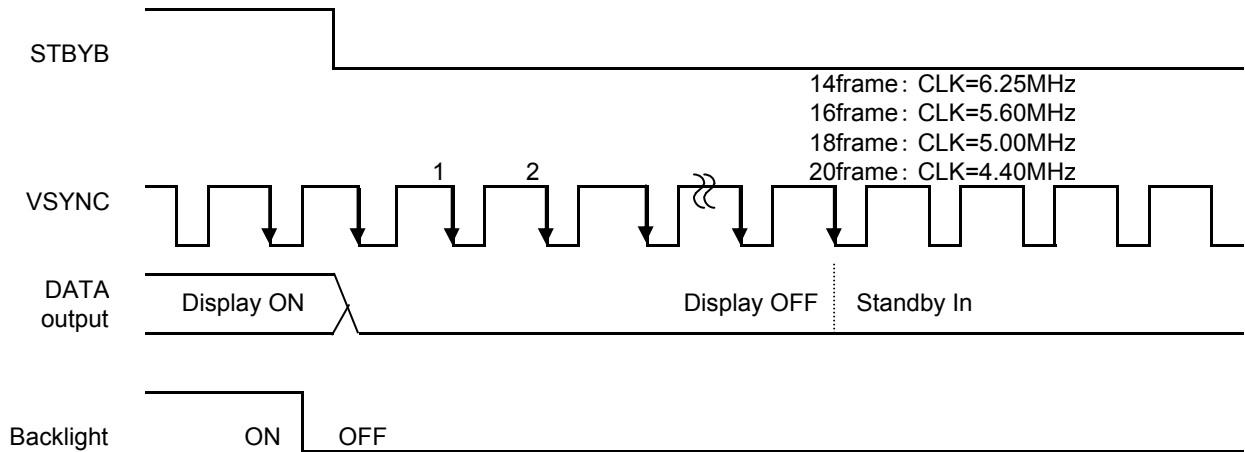

8.6 Reset Sequence

There is a limitation between the power supply turning on and the RESETB input. Please defend the following conditions.

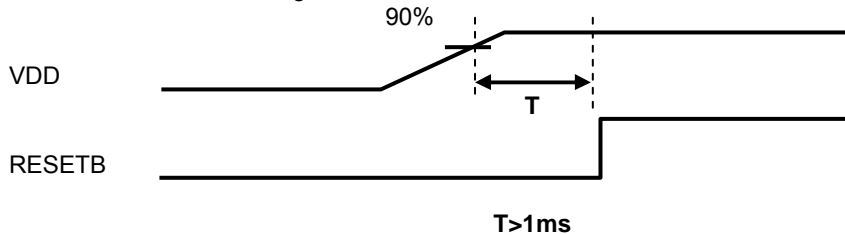

9. CIRCUIT

9.1 Touch Panel Circuit

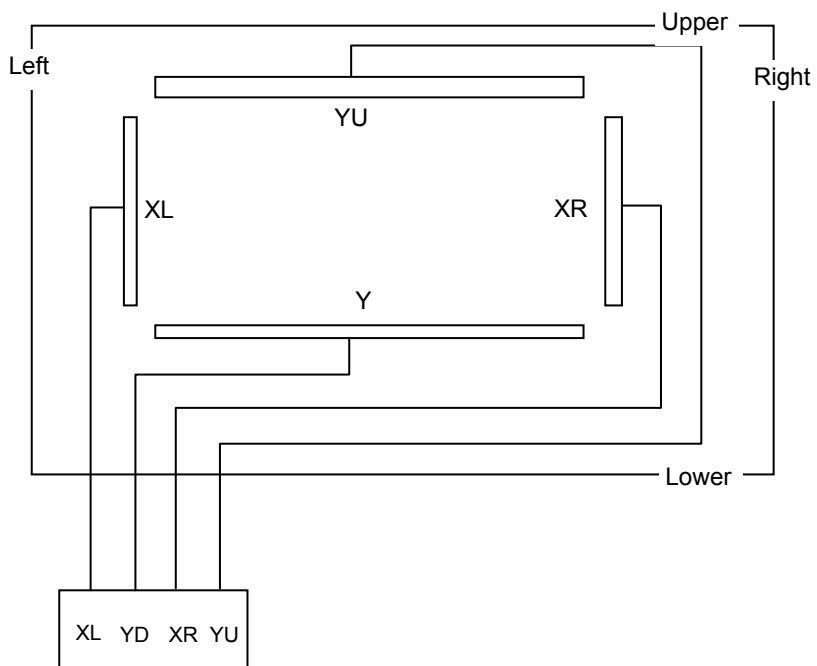

9.2 LED Circuit

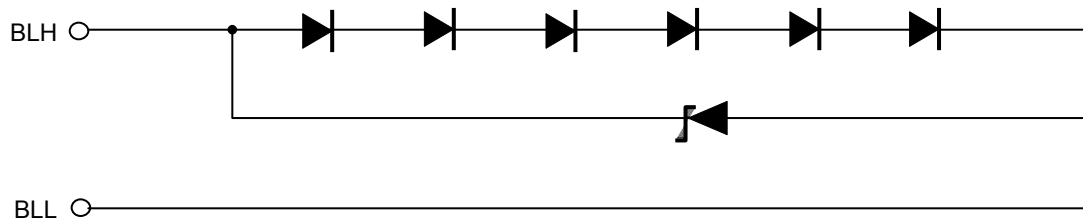

10. CHARACTERISTICS

10.1 Optical Characteristics

< Measurement Condition >

Measuring instruments: CS1000 (KONICA MINOLTA) , LCD7200(OTSUKA ELECTRONICS) ,
EZcontrast160D (ELDIM)Driving condition: VDD = 3.0V, VSS = 0V
Optimized VCOMDC

Backlight: IL=6.5mA

Measured temperature: Ta = 25° C

Item	Symbol	Condition	MIN	TYP	MAX	Unit	Note No.	Remark	
Response time	Rise time	TON	[Data]= 3Fh→00h	—	—	40	ms	1	※
	Fall time	TOFF	[Data]= 00h→3Fh	—	—	60	ms		
Contrast ratio	Backlight ON	CR	[Data]= 3Fh/00h	240	400	—		2	
	Backlight OFF			—	1.9	—			
Viewing angle	Left	θL	[Data]= 3Fh/00h CR ≥ 10	80	—	—	deg	3	※
	Right	θR		80	—	—	deg		
	Up	ϕU		80	—	—	deg		
	Down	ϕD		80	—	—	deg		
White Chromaticity	x	[Data]=3Fh	White chromaticity range				4		
	y								
Burn-in			No noticeable burn-in image shall be observed after 2 hours of window pattern display.				5		
Center brightness		[Data]=3Fh	130	190	—	cd/m ²	6		
Brightness distribution		[Data]=3Fh	70	—	—	%	7		

* Note number 1 to 7: Refer to the APPENDIX of "Reference Method for Measuring Optical Characteristics".

※ Measured in the form of LCD module.

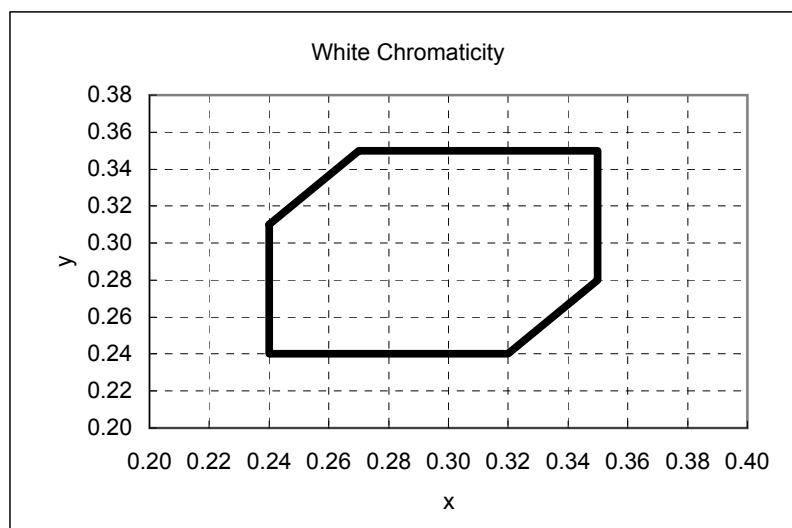

【White Chromaticity Range】

x	y
0.24	0.31
0.24	0.24
0.32	0.24
0.35	0.28
0.35	0.35
0.27	0.35

10.2 Temperature Characteristics

< Measurement Condition >

Measuring instruments: CS1000 (KONICA MINOLTA) , LCD7200(OTSUKA ELECTRONICS)

Driving condition: VDD = 3.0V, VSS = 0V

Optimized VCOMDC

Backlight: IL=6.5mA

Item			Specification		Remark
			Ta = -20°C	Ta = 70°C	
Contrast ratio		CR	40 or more	40 or more	Backlight ON
Response time	Rise time	TON	200 msec or less	30 msec or less	※
	Fall time	TOFF	300 msec or less	50 msec or less	※
Display Quality			No noticeable display defect or nonuniformity should be observed.		Use the criteria for judgment specified in the section 11.

※ Measured in the form of LCD module.

11. CRITERIA OF JUDGMENT

11.1 Defective Display and Screen Quality

Test Condition: Observed TFT-LCD monitor from front during operation with the following conditions

Driving Signal Raster Pattern (RGB, white, black)
 Signal condition [Data] : 3Fh, 22h, 00h (3 steps)
 Observation distance 30 cm
 Illuminance 200 to 350 lx
 Backlight IL = 6.5mA

Defect item	Defect content	Criteria	
Display Quality	Line defect	Black, white or color line, 3 or more neighboring defective dots	
	Dot defect	Uneven brightness on dot-by-dot base due to defective TFT or CF, or dust is counted as dot defect (brighter dot, darker dot)	
		High bright dot: Visible through 2% ND filter at [Data]=00h Low bright dot: Visible through 5% ND filter at [Data]=00h Dark dot: Appear dark through white display at [Data]=22h Invisible through 5% ND filter at [Data]=00h	
Screen Quality	Dirt	Uneven brightness (white stain, black stain etc)	
	Foreign particle	Point-like	$0.25\text{mm} < \phi$
			$0.20 < \phi \leq 0.25\text{mm}$
			$\phi \leq 0.20\text{mm}$
	Flaw	Liner	$3.0\text{mm} < \text{length and } 0.08\text{mm} < \text{width}$
			$\text{length} \leq 3.0\text{mm}$ or $\text{width} \leq 0.08\text{mm}$
			$0.05\text{mm} < W$
	Flaw	Flaw on the surface of the Touch panel	$0.03 < W \leq 0.05\text{mm}$ $2 < L \leq 5\text{mm}$
			$L \leq 2\text{mm}$
			$W \leq 0.03\text{mm}$
Others		Use boundary sample for judgment when necessary	

ϕ (mm): Average diameter = (major axis + minor axis)/2
 Permissible number: N

Table 1

Area	High bright dot	Low bright dot	Dark dot	Total	Criteria
A	0	2	2	3	Permissible distance between same color bright dots (includes neighboring dots): 3 mm or more Permissible distance between same color high bright dots (includes neighboring dots): 5 mm or more
B	2	4	4	6	
Total	2	4	4	7	

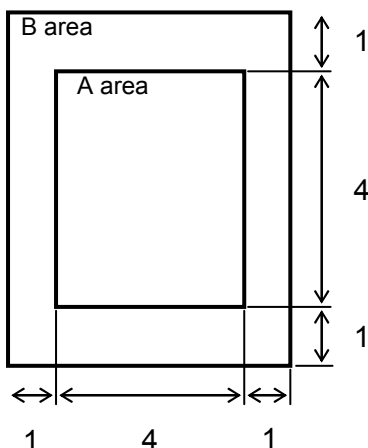

Division of A and B areas
 B area: Active area
 Dimensional ratio between A and B areas: 1: 4: 1 (Refer to the left figure)

11.2 Screen and Other Appearance

Testing conditions

Illuminance	1200~2000 lx
Observation distance	30cm

Item	Criteria	Remark
Polarizer Flaw Stain Bubble Dust Dent	Ignore invisible defect when the backlight is on.	Applicable area: Active area only (Refer to the section 3.2 "Outward form")
S-case	No functional defect occurs	
FPC cable	No functional defect occurs	

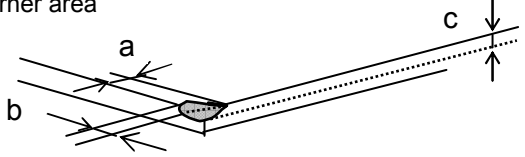
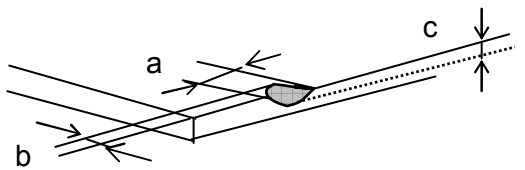
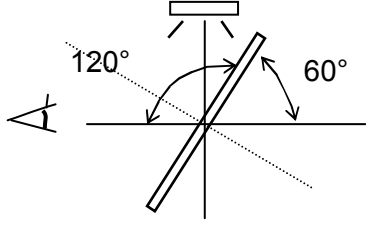
Item	Appearance	Criteria
Touch Panel	Corner area 	Unit:mm $a \leq 3$ $b \leq 3$ $c \leq t$ (t: glass thickness) $a, b \leq 0.5$ is ignored $n \leq 2$
	Others 	Unit:mm $a \leq 5$ $b \leq 1$ $c \leq t$ (t:glass thickness) $a, b \leq 0.5$ is ignored Maximum permissible number of chipping off on a side is 5.
	Progressive crack	Any of them is rejected
	Interference fringe Concentric interference fringe (Test method) Observe the Panel surface from 60 degrees angle to the surface under white fluorescent lamp (Triple wavelength lamp) 	Average diameter $d \leq 8$ mm is acceptable. Darkness: comply with the boundary sample

12. RELIABILITY TEST

Test item		Test condition		number of failures /number of examinations
Durability test	High temperature storage	Ta=80°C	240hr	0/3
	Low temperature storage	Ta=-30°C	240hr	0/3
	High temperature & high humidity storage	Ta=60°C, RH=90% non condensing	240hr	0/3
	High temperature operation	Tp=70°C	240hr	0/3
	Low temperature operation	Tp=-20°C	240hr	0/3
	High temp & humid operation	Tp=40°C, RH=90% non condensing	240hr	0/3
	Thermal shock storage	-30←→80°C(30min/30min)	100 cycles	0/3
Mechanical environmental test	Electrostatic discharge test (Non operation)	Confirms to EIAJ ED-4701/300 C=200pF, R=0Ω, V=±200V Each 3 times of discharge on and power supply and other terminals.		0/3
	Surface discharge test (Non operation)	C=250pF, R=100Ω, V=±12kV Each 5 times of discharge in both polarities on the center of screen with the case and Touch Panel terminal grounded.		0/3
	Vibration test	Total amplitude 1.5mm, f=10 ~55Hz, X,Y,Z directions for each 2 hours		0/3
	Impact test	Use ORTUS TECHNOLOGY original jig (see next page) and make an impact with peak acceleration of 1000m/s ² for 6 msec with half sine-curve at 3 times to each X, Y, Z directions in conformance with JIS 60068-2-27-2011.		0/3
Packing test	Packing vibration-proof test	Acceleration of 19.6m/s ² with frequency of 10→55→10Hz, X,Y, Zdirection for each 30 minutes		0/1 Packing
	Packing drop test	Drop from 75cm high. 1 time to each 6 surfaces, 3 edges, 1 corner		0/1 Packing

Note: Ta=ambient temperature Tp=Panel temperature

※ The profile of high temperature/humidity storage and High Temperature/humidity operation (Pure water of over 10MΩ·cm shall be used.)

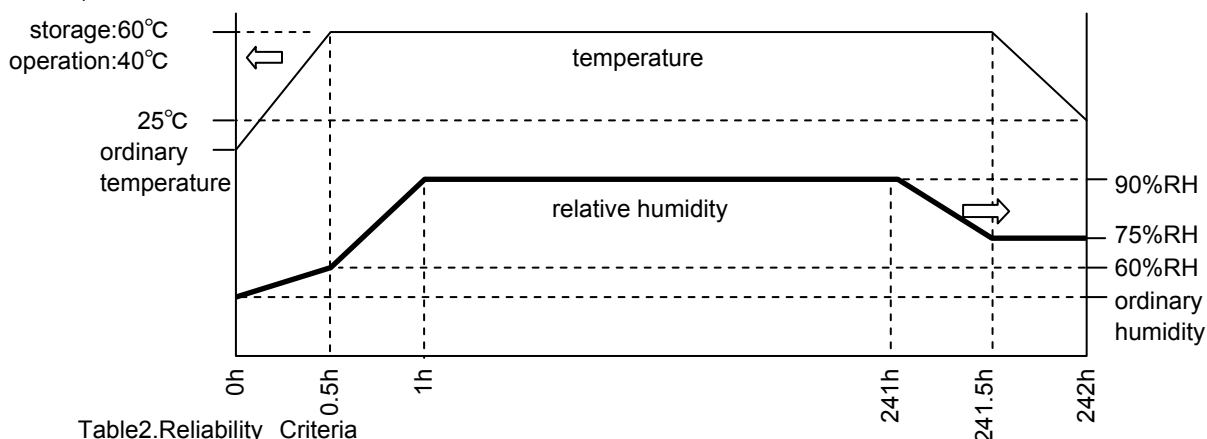
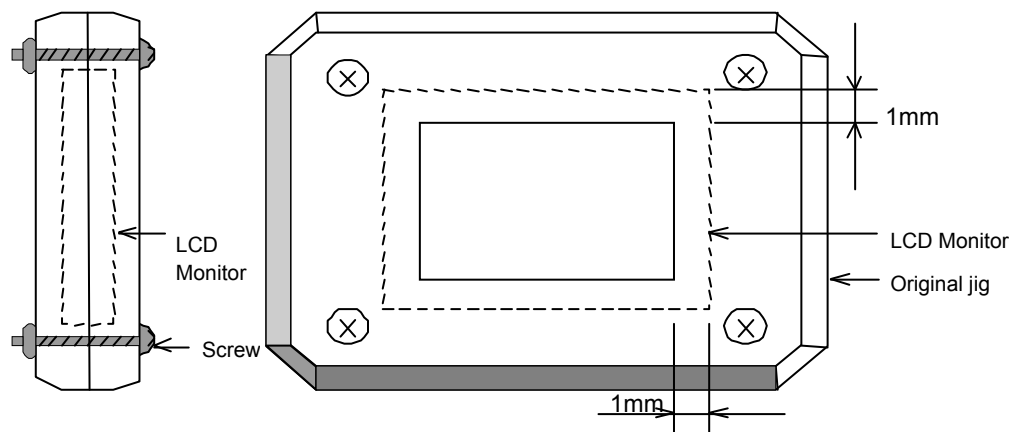

Table2.Reliability Criteria

Measure the parameters after leaving the monitor at the ordinary temperature for 24 hours or more after the test completion.

Item	Standard	Remarks
Display quality	No visible abnormality shall be seen.	As criteria of 11 "CRITERIA OF JUDGMENT".
Contrast ratio	40 or more	Backlight ON

ORTUS TECHNOLOGY Original Jig



13. PACKING SPECIFICATIONS

Packing specification
(S=FREE)

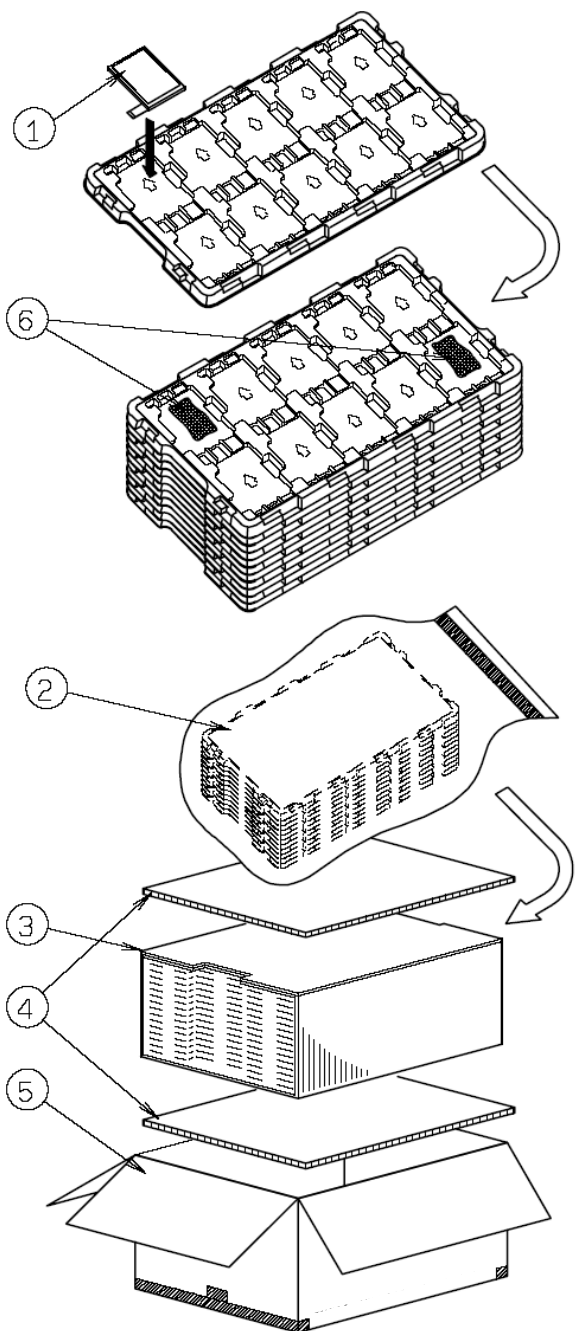

- Step 1 Each product is to be placed in one of the cut-outs of the tray with the display surface facing upward.
(8 products per tray)
- Step 2 Each tray needs to be same orientation respect to the tray below or above it and the trays be in a stack of 10.
One empty tray is to be put on the top of stack of 10 trays.
- Step 3 2 packs of moisture absorbers are to be placed on the top tray as shown in the drawing.
Put piled trays into a sealing bag.
Vacuum and seal the sealing bag with the vacuum sealing machine.
- Step 4 The stack of trays in the plastic back is to be inserted into a inner carton.
- Step 5 A corrugated board is to be placed on the top and on the bottom of the inner carton.
The two corrugated boards and the inner carton is to be inserted into an outer carton.
- Step 6 The outer carton needs to sealed with packing tape as shown in the drawing.
The model number, quantity of products, and shipping date are to be printed on the outer carton.
If necessary, shipping labels or impression markings are to be put on the outer carton.
- Step 7 The outer carton is to be inserted into a extra outer carton with same direction.
The extra outer carton needs to sealed with packing tape as shown in the drawing.
- Step 8 The model number, quantity of products, and shipping date are to be printed on the extra outer carton.
If necessary, shipping labels or impression markings are to be put on the extra outer carton.

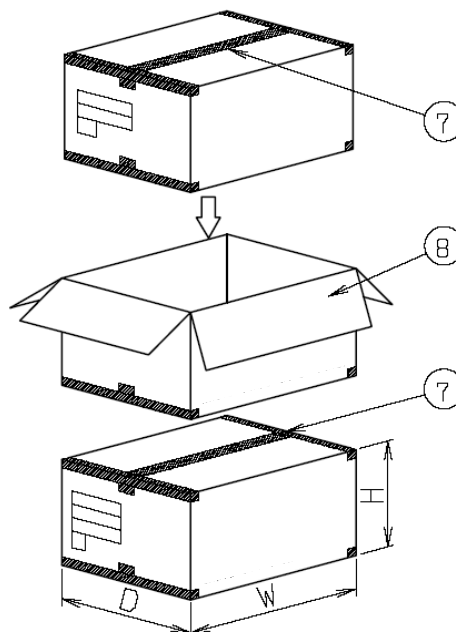

Remark: The return of packing materials is not required.

Packing item name	Specs., Material
① Tray	PP Conductive
② Inner carton	Corrugated cardboard
③ Inner board	Corrugated cardboard
④ Outer carton	Corrugated cardboard
⑤ Sealing bag	
⑥ Drier	Moisture absorber
⑦ Packing tape	
⑧ Extra outer carton	Corrugated cardboard

Dimension of extra outer carton	
D : Approx.	(338mm)
W : Approx.	(549mm)
H : Approx.	(198mm)
Quantity of products packed in one carton	10pcs×10=100pcs
Gross weight : Approx.	7.7Kg

14. HANDLING INSTRUCTION

14.1 Cautions for Handling LCD panels

**Caution**

- (1) Do not make an impact on the LCD panel glass because it may break and you may get injured from it.
- (2) If the glass breaks, do not touch it with bare hands.
(Fragment of broken glass may stick you or you cut yourself on it.)
- (3) If you get injured, receive adequate first aid and consult a medical doctor.
- (4) Do not let liquid crystal get into your mouth.
(If the LCD panel glass breaks, try not let liquid crystal get into your mouth even toxic property of liquid crystal has not been confirmed.)
- (5) If liquid crystal adheres, rinse it out thoroughly.
(If liquid crystal adheres to your cloth or skin, wipe it off with rubbing alcohol or wash it thoroughly with soap. If liquid crystal gets into eyes, rinse it with clean water for at least 15 minutes and consult an eye doctor.)
- (6) If you scrap this products, follow a disposal standard of industrial waste that is legally valid in the community, country or territory where you reside.
- (7) Do not connect or disconnect this product while its application products is powered on.
- (8) Do not attempt to disassemble or modify this product as it is precision component.
- (9) If a part of soldering part has been exposed, and avoid contact (short-circuit) with a metallic part of the case etc. about FPC of this model, please.
Please insulate it with the insulating tape etc. if necessary.
The defective operation is caused, and there is a possibility to generation of heat and the ignition.
- (10) Since excess current protection circuit is not built in this TFT module, there is the possibility that LCD module or peripheral circuit become feverish and burned in case abnormal operation is generated.
We recommend you to add excess current protection circuit to power supply.
- (11) The end part of glass and film of touch panel has conductivity, and avoid contact (short-circuit) with electroconductive case etc.. There is a possibility of setting up a defective touch panel, and insulate it for the case suppression (cushion etc.) if necessary, please.

**Caution**

This mark is used to indicate a precaution or an instruction which, if not correctly observed, may result in bodily injury, or material damages alone.

14.2 Precautions for Handling

- 1) Wear finger tips at incoming inspection and for handling the TFT monitors to keep display quality and keep the working area clean.
Do not touch the surface of the monitor as it is easily scratched.
- 2) Wear grounded wrist-straps and use electrostatic neutralization blowers to prevent static charge and discharge when handling the TFT monitors as the LED in this TFT monitors is damageable to electrostatic discharge,
Properly set up equipment, jigs and machines, and keep working area clean and tidy for handling the TFT monitors.
- 3) Avoid strong mechanical shock including knocking, hitting or dropping to the TFT monitors for protecting their glass parts. Do not use the TFT monitors that have been experienced dropping or strong mechanical shock.
- 4) Do not use or storage the TFT monitors at high temperature and high humidity environment. Particularly, never use or storage the TFT monitors at a location where condensation builds up.
- 5) Avoid using and storing TFT monitors at a location where they are exposed to direct sunlight or ultraviolet rays to prevent the LCD panels from deterioration by ultraviolet rays.
- 6) Do not stain or damage the contacts of the FPC cable .
FPC cable needs to be inserted until it can reach to the end of connector slot.
During insertion, make sure to keep the cable in a horizontal position to avoid an oblique insertion.
Otherwise, it may cause poor contact or deteriorate reliability of the FPC cable.
- 7) The FPC cable is a design very weak to the bend and the pull as it is fixed with the tape.
Do not bend or pull the FPC cable or carry the TFT monitor by holding the FPC cable.
- 8) Peel off the protective film on the TFT monitors during mounting process.
Refer to the section 14.5 on how to peel off the protective film.
We are not responsible for electrostatic discharge failures or other defects occur when peeling off the protective film.

14.3 Precautions for Operation

- 1) Since this TFT monitors are not equipped with light shielding for the driver IC, do not expose the driver IC to strong lights during operation as it may cause functional failures.
- 2) In case of powering up or powering off this LCD module, be sure to comply the sequence as instructed in this specification.
- 3) Do not plug in or out the FPC cable while power supply is switch on.
Plug the FPC cable in and out while power supply is switched off.
- 4) Do not operate the TFT monitors in the strong magnetic field. It may break the TFT monitors.
- 5) Do not display a fixed image on the screen for a long time.
Use a screen-saver or other measures to avoid a fixed image displayed on the screen for a long time. Otherwise, it may cause burn-in image on the screen due the characteristics of liquid crystal.

14.4 Storage Condition for Shipping Cartons

Storage environment

- Temperature 0 to 40° C
- Humidity 60%RH or less
- Atmosphere No-condensing occurs under low temperature with high humidity condition. No poisonous gas that can erode electronic components and/or wiring materials should be detected.
- Time period 3 months
- Unpacking To protect the TFT monitors from static damage during unpacking, keep room humidity more than 50%RH and implement effective countermeasures against static electricity such as establishing a ground (an earth) before unpacking.
- Maximum piling up 7 cartons

14.5 Precautions for Peeling off the Protective film

The followings work environment and work method are recommended to prevent the TFT monitors from static damage or adhesion of dust when peeling off the protective films.

A) Work Environment

- a) Humidity: 50 to 70 %RH, Temperature 15° C to 27° C
- b) Operators should wear conductive shoes, conductive clothes, conductive finger tips and grounded wrist-straps. Anti-static treatment should be implemented to work area's floor.
- c) Use a room shielded against outside dust with sticky floor mat laid at the entrance to eliminate dirt.

B) Work Method

The following procedures should taken to prevent the driver ICs from charging and discharging.

- a) Use an electrostatic neutralization blower to blow air on the TFT monitors to its lower left when the LCD-FPC cable is facing to the leftside. Optimize direction of the blowing air and the distance between the TFT monitors and the electrostatic neutralization blower.
- b) Put an adhesive tape (Scotch tape, etc) at the lower left corner area of the protective film to prevent scratch on surface of TFT monitors.
- c) Peel off the adhesive tape slowly (spending more than 2 secs to complete) by pulling it to opposite direction.

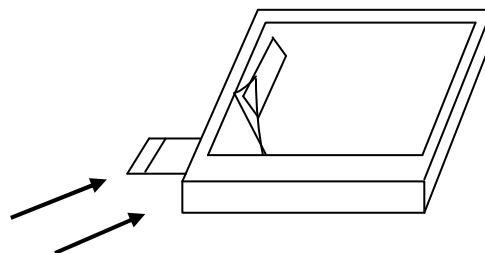

Direction of blowing air
(Optimize air direction and the distance)

APPENDIX

Reference Method for Measuring Optical Characteristics and Performance

1. Measurement Condition (Backlight ON)

Measuring instruments: CS1000(KONICA MINOLTA), LCD7200(OTSUKA ELECTRONICS), EZcontrast160D(ELDIM)

Driving condition: Refer to the section "Optical Characteristics"

Measured temperature: 25° C unless specified

Measurement system: See the chart below. The luminance meter is placed on the normal line of measurement system.

Measurement point: At the center of the screen unless otherwise specified

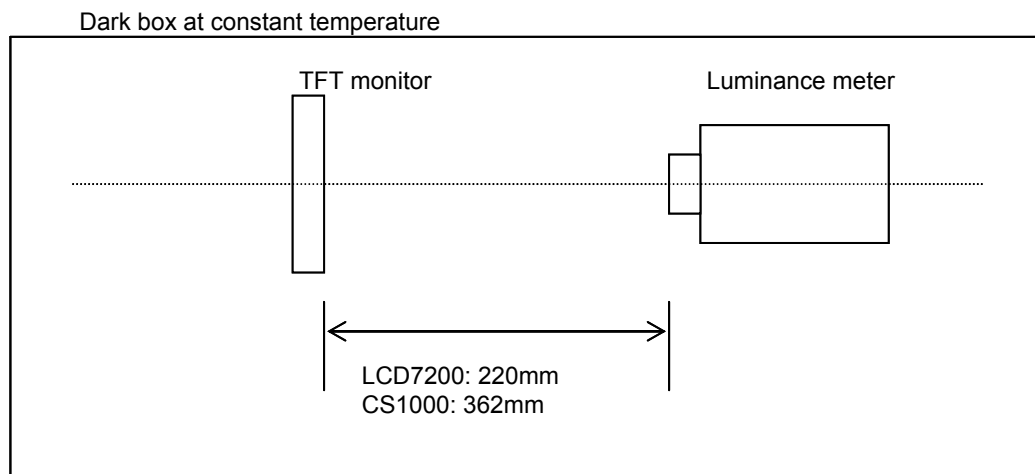

Measurement is made after 30 minutes of lighting of the backlight.

Measurement point: At the center point of the screen
Brightness distribution: 9 points shown in the following drawing.

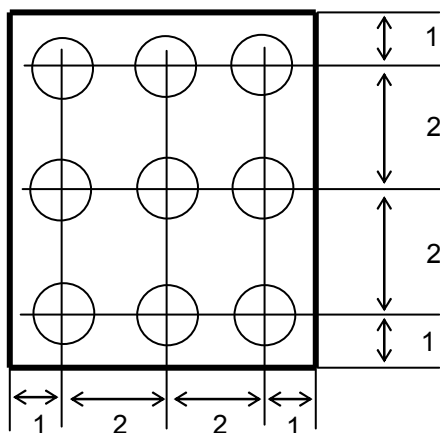

Dimensional ratio of active area

Backlight IL = 6.5mA

Measurement Condition (Contrast ratio Backlight OFF only)

Measuring instruments: LCD7200(OTSUKA ELECTRONICS), Ring Light(40,000 lx, $\phi 58$)

Driving condition: Refer to the section "Optical Characteristics"

Measured temperature: 25° C unless specified

Measurement system: See the chart below.

Measurement point: At the center of the screen.

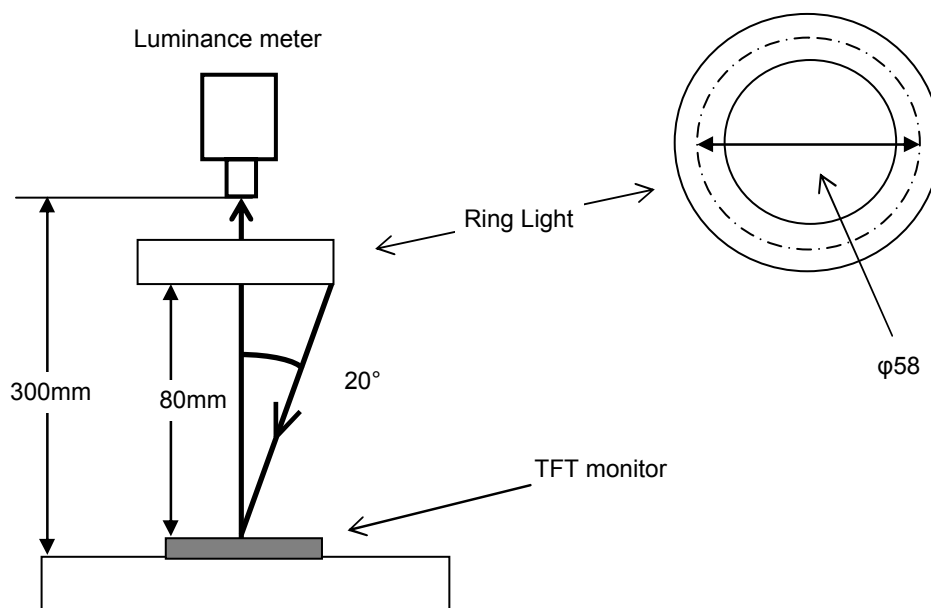

2. Test Method

Notice	Item	Test method	Measuring instrument	Remark
1	Response time	<p>Measure output signal waveform by the luminance meter when raster of window pattern is changed from white to black and from black to white.</p>	LCD7200	Black display [Data]=00h White display [Data]=3Fh TON Rise time TOFF Fall time
2	Contrast ratio	<p>Measure maximum luminance Y1([Data]=3Fh) and minimum luminance Y2([Data]=00h) at the center of the screen by displaying raster or window pattern. Then calculate the ratio between these two values. Contrast ratio = Y1/Y2 Diameter of measuring point: 8mm ϕ (CS1000) Diameter of measuring point: 3mm ϕ (LCD7200)</p>	CS1000 LCD7200	Backlight ON Backlight OFF
3	Viewing angle Horizontal θ Vertical ϕ	Move the luminance meter from right to left and up and down and determine the angles where contrast ratio is 10.	EZcontrast160D	
4	White chromatically	<p>Measure chromaticity coordinates x and y of CIE1931 colorimetric system at [Data] = 3Fh Color matching faction: 2°view</p>	CS1000	
5	Burn-in	Visually check burn-in image on the screen after 2 hours of "window display" ([Data]=3Fh/00h).		At optimized Vcom/C
6	Center brightness	Measure the brightness at the center of the screen.	CS1000	
7	Brightness distribution	<p>(Brightness distribution) = 100 x B/A % A : max. brightness of the 9 points B : min. brightness of the 9 points</p>	CS1000	

* Linearity Measurement of Touch Panel

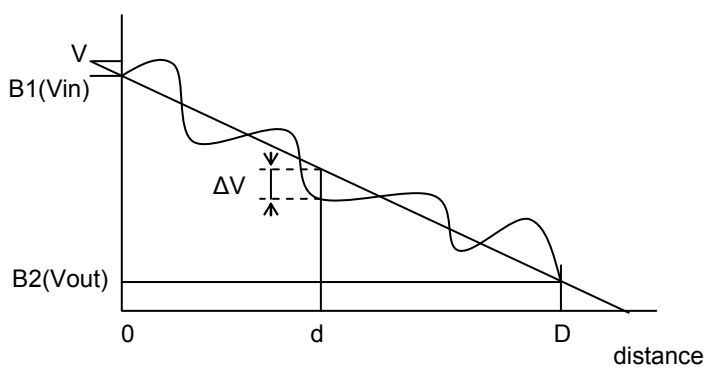

$$LE(\%) = \Delta V / (V_{in} - V_{out})$$

$$LE_{max}(\%) = \Delta V_{max} / (V_{in} - V_{out})$$

■ Cautionary instruction to handle a Touch-panel

● Cushion (between Touch Panel Chassis) Design

- 1) A cushion is required to be placed between Touch Panel and customer's chassis and there is a designated area to attach it. Attachment at area inside Input Prohibition Area must be forbidden.
If cushion was located inside Input Prohibition Area, Upper Electrode may be push constantly and which may cause the electrode breakage at the position falling on the edge of adhesive; it eventually results in Touch Panel malfunction in the future. (Please see "NG-1")
- 2) Be attention to the cushion material you use. In the case that too soft cushion was used, the cushion may protrude into Prohibition Area by being push strongly; which may result in the electrode breakage. Eventually there is a chance that the electrode breakage leads to the malfunction of Touch Panel in the future. (Please see "NG-2")
- 3) Cushion is required to be attached at the side of Customer's chassis.
Attaching a cushion at the side of Upper Electrode Film has a chance to deform the film and lead to the malfunction of Touch Panel in the future.

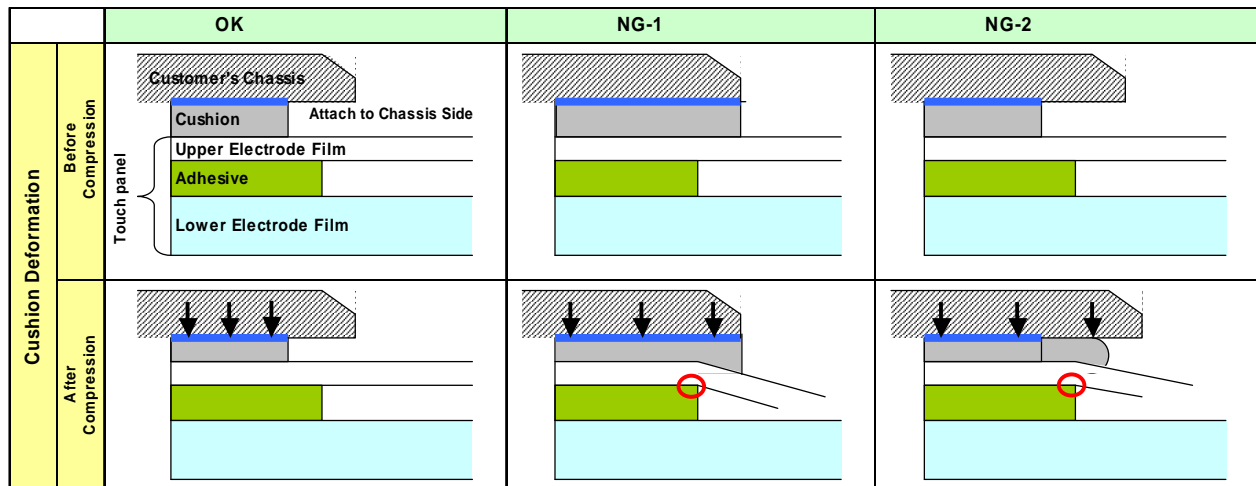

● Design Guidance of Chassis (Front Part)

- 4) Be attention to stay Input Prohibition Area away from touching and/or drawing by a stylus pens in order to avoid the electrode breakage and potential malfunction of Touch Panel. (Please see "NG-3")
We recommend customers to design chassis (front case) being able to protect Input Prohibition Area.
- 5) Clearance between customer's chassis and Touch Panel surface is certainly required in order to avoid erroneous input caused by a collision of the edge of chassis. (Please see "NG-4")
A clearance of 0.3 to 0.7mm is recommended.

● Design Guidance of Chassis (Side Part)

- 6) Upper Electrode and Lower Electrode fall on the edge of Touch Panel outline.
Redundant design having enough clearance to avoid electric short with chassis is highly recommended. (Please see "NG-5")

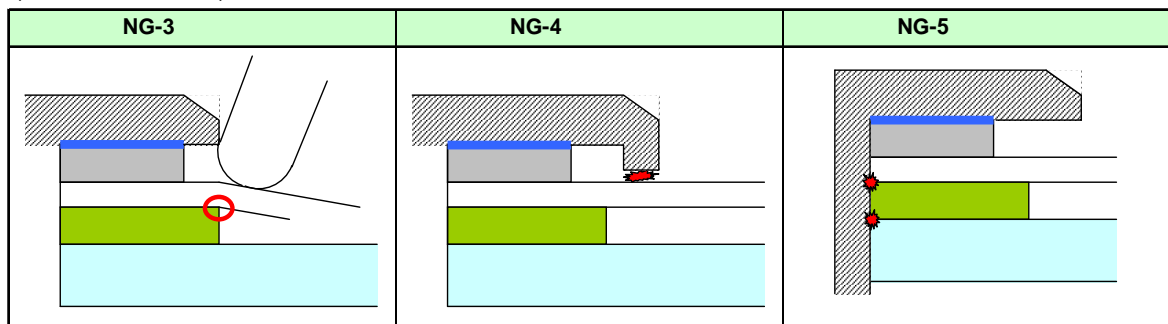

● Example of Recommended Chassis Design

Refer to "3.2 Outward Form".

- As a terminal resistance has individual specificity, calibration to align the displaying and the sensing position one each is mandatory before use.